

料表编号:

- 绑扎
- 配料
- 留存

# 恒坪房地产开发有限公司

项目: 恒大, 深林海

栋号: 6#楼

部位: 基础\_柱插筋

相同层数: 1

序号	分类	Φ8	Φ10	Φ12	Φ14	Φ16	Φ18	Φ20	Φ25	合计
1	重量	1406	161	457	76	4616	6458	2315	197	15.686

注:重量单位明细为公斤、合计为吨;接头单位为个。

混凝土标号 C45

抗震等级 一级

锚固 32d

暗柱在承台梁内设置三道稳定箍筋, 仅设外围箍

日期: 2018年04月23日



# 钢筋配料表

1级C45锚固28, 26, 32, 39

栋号: 6#楼

部位: 基础\_柱插筋

构件名称	级直 别径	钢筋简图	下料 (mm)	根件 数*数	总 根数	重量 (kg)	备注
西单元							
<div style="display: flex; justify-content: space-between; align-items: flex-start;"> <div style="border: 1px solid black; padding: 5px;"> <p>① ② ①</p> <p>② ②</p> <p>① ①</p> <p>② ②</p> <p>① ② ①</p> </div> <div style="text-align: center;"> <p>1AZ1 <math>\Phi 8@150</math></p> </div> <div style="text-align: right;"> <p><math>\Phi 8: 200 \times 250</math></p> <p><math>\Phi 8: 250 \times 700</math></p> <p><math>\Phi 8: L250</math></p> </div> </div> <p style="margin-top: 20px;">1: <math>\Phi 16 \ 150 \ \lrcorner \ 2880</math></p> <p>2: <math>\Phi 16 \ 150 \ \lrcorner \ 2130</math></p>							
1AZ1	$\Phi 16$	150 $\lrcorner$ 2130	2250	6	6	21.33	下插920
	$\Phi 16$	150 $\lrcorner$ 2880	3000	6	6	28.44	同上
	$\Phi 8$	200  250	1040	3	3	1.23	
	$\Phi 8$	250  700	2040	5	5	4.03	
	$\Phi 8$	$\lrcorner$ 250	410	3	3	0.49	
<div style="display: flex; justify-content: space-between; align-items: flex-start;"> <div style="border: 1px solid black; padding: 5px;"> <p>① ② ①</p> <p>② ②</p> <p>① ② ①</p> </div> <div style="text-align: center;"> <p>1AZ2 <math>\Phi 8@150</math></p> </div> <div style="text-align: right;"> <p><math>\Phi 8: 250 \times 350</math></p> <p><math>\Phi 8: L250</math></p> </div> </div> <p style="margin-top: 20px;">1: <math>\Phi 14 \ 150 \ \lrcorner \ 2880</math></p> <p>2: <math>\Phi 14 \ 150 \ \lrcorner \ 2130</math></p>							
1AZ2	$\Phi 14$	150 $\lrcorner$ 2130	2250	4	4	10.89	下插920
	$\Phi 14$	150 $\lrcorner$ 2880	3000	4	4	14.52	同上
	$\Phi 8$	250  350	1340	5	5	2.65	
	$\Phi 8$	$\lrcorner$ 250	410	3	3	0.49	

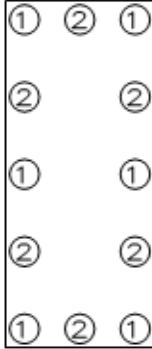
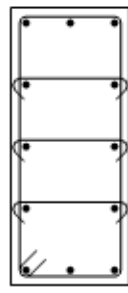
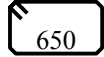
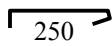
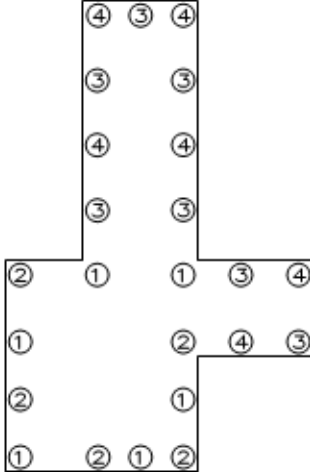
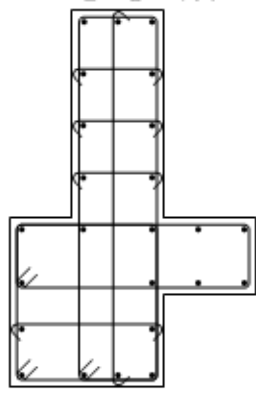
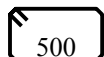
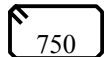
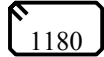
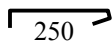
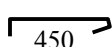
构件名称	级直径	钢筋简图	下料 (mm)	根件 数*数	总 根数	重量 (kg)	备注
		 <p>1GBZ1 <math>\Phi 8@150</math></p> <p>1: <math>\Phi 18</math> 150 <math>\lrcorner</math> 2890 2: <math>\Phi 18</math> 150 <math>\lrcorner</math> 2140</p>  <p><math>\Phi 8</math>: 250x650 <math>\Phi 8</math>: L250</p>					
1GBZ1	$\Phi 18$	150 $\lrcorner$ 2140	2250	6	6	27.00	下插920
	$\Phi 18$	150 $\lrcorner$ 2890	3000	6	6	36.00	同上
	$\Phi 8$	250 	1940	5	5	3.83	
	$\Phi 8$		410	9	9	1.46	
		 <p>1GBZ2 <math>\Phi 8@150</math></p> <p>1: <math>\Phi 20</math> 150 <math>\lrcorner</math> 2890 2: <math>\Phi 20</math> 150 <math>\lrcorner</math> 2140 3: <math>\Phi 18</math> 150 <math>\lrcorner</math> 2140 4: <math>\Phi 18</math> 150 <math>\lrcorner</math> 2890</p>  <p><math>\Phi 8</math>: 450x500 <math>\Phi 8</math>: 200x750 <math>\Phi 8</math>: 250x1180 <math>\Phi 8</math>: L250 <math>\Phi 8</math>: L450 <math>\Phi 8</math>: L1170</p>					
1GBZ2	$\Phi 20$	150 $\lrcorner$ 2140	2250	5	5	27.79	下插920
	$\Phi 18$	150 $\lrcorner$ 2140	2250	7	7	31.50	同上
	$\Phi 20$	150 $\lrcorner$ 2890	3000	6	6	44.46	同上
	$\Phi 18$	150 $\lrcorner$ 2890	3000	6	6	36.00	同上
	$\Phi 8$	450 	2040	5	5	4.03	
	$\Phi 8$	200 	2040	5	5	4.03	
	$\Phi 8$	250 	3000	5	5	5.93	
	$\Phi 8$		410	9	9	1.46	
	$\Phi 8$		610	3	3	0.72	

构件名称	级直径	钢筋简图	下料 (mm)	根件 数*数	总 根数	重量 (kg)	备注
	Φ8		1330	3	3	1.58	

1GBZ3 Φ8@150

Φ8: 200x1550  
Φ8: 450x500  
Φ8: 250x600  
Φ8: 250x850  
Φ8: L200  
Φ8: L250  
Φ8: L450  
Φ8: L850

1: Φ18 150┐ 2890

2: Φ18 150┐ 2140

3: Φ20 150┐ 2890

4: Φ20 150┐ 2140

1GBZ3	Φ18	150┐ 2140	2250	12	12	54.00	下插920
	Φ20	150┐ 2140	2250	5	5	27.79	同上
	Φ18	150┐ 2890	3000	11	11	66.00	同上
	Φ20	150┐ 2890	3000	6	6	44.46	同上
	Φ8	200┐ 1550	3640	5	5	7.19	
	Φ8	450┐ 500	2040	5	5	4.03	
	Φ8	250┐ 600	1840	5	5	3.63	
	Φ8	250┐ 850	2340	5	5	4.62	
	Φ8		360	6	6	0.85	
	Φ8		410	6	6	0.97	
	Φ8		610	3	3	0.72	
	Φ8		1010	3	3	1.20	

1GBZ4 Φ8@150

Φ8: 200x650  
Φ8: 250x500  
Φ8: L200

1: Φ18 150┐ 2890

2: Φ16 150┐ 2130

3: Φ18 150┐ 2140

4: Φ16 150┐ 2880

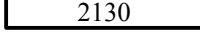
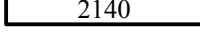
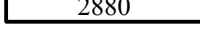
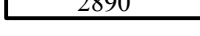
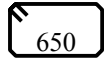
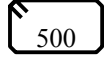
构件名称	级直径	钢筋简图	下料 (mm)	根 数*数	总 根数	重量 (kg)	备 注
1GBZ4	Φ16	150 	2250	4	4	14.22	下插920
	Φ18	150 	2250	4	4	18.00	同上
	Φ16	150 	3000	2	2	9.48	同上
	Φ18	150 	3000	6	6	36.00	同上
	Φ8	200 	1840	5	5	3.63	
	Φ8	250 	1640	5	5	3.24	
	Φ8		360	6	6	0.85	

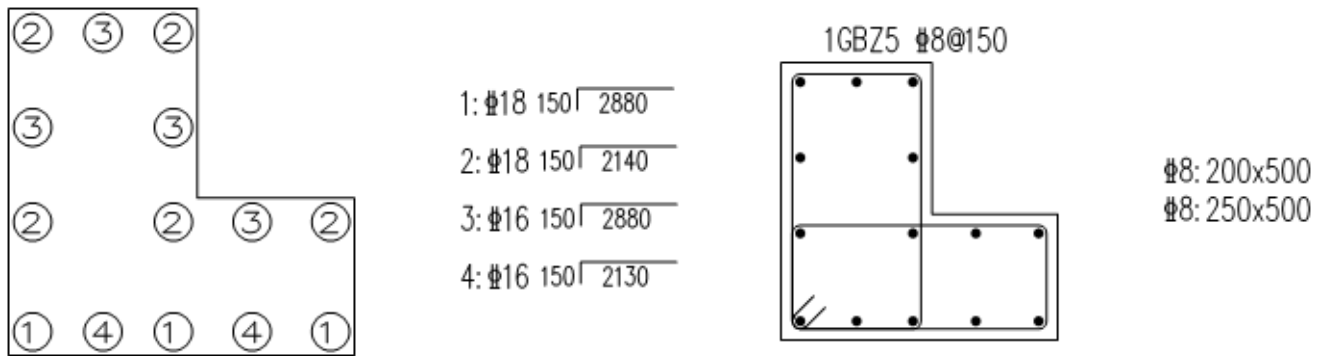

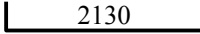
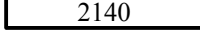
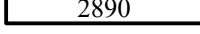
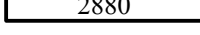
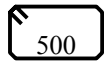
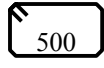
1GBZ5	Φ16	150 	2250	2	2	7.11	下插920
	Φ18	150 	2250	5	5	22.50	同上
	Φ18	150 	3000	3	3	18.00	同上
	Φ16	150 	3000	4	4	18.96	同上
	Φ8	200 	1540	5	5	3.04	
	Φ8	250 	1640	5	5	3.24	

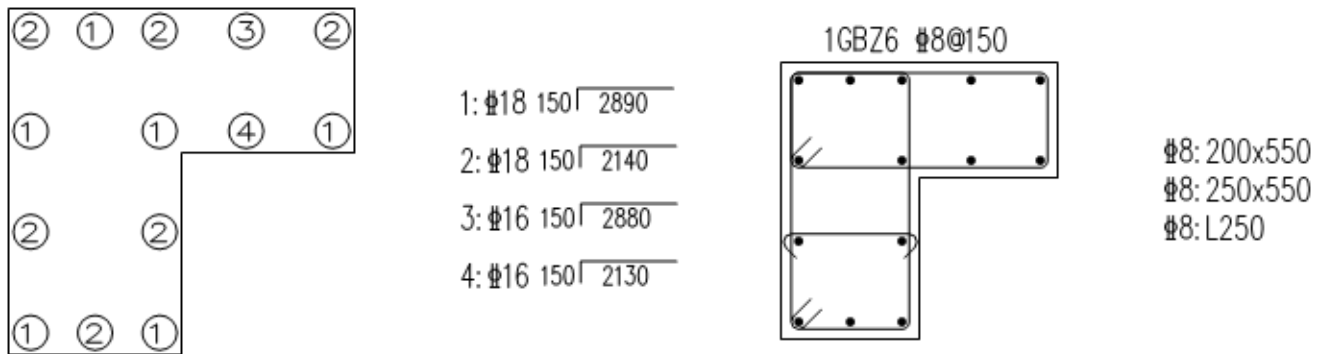

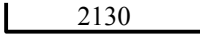
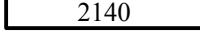
1GBZ6	Φ16	150 	2250	1	1	3.56	下插920
	Φ18	150 	2250	6	6	27.00	同上



审核:

翻样: 钟祥祯13653434429

第 4 页,共43页

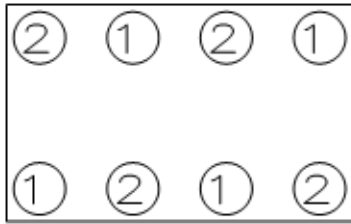
构件名称	级直别径	钢筋简图	下料(mm)	根件数*数	总根数	重量(kg)	备注
	Φ16	150 	3000	1	1	4.74	同上
	Φ18	150 	3000	6	6	36.00	同上
	Φ8	200 	1640	5	5	3.24	
	Φ8	250 	1740	5	5	3.44	
	Φ8		410	3	3	0.49	



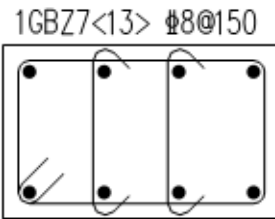

1: Φ16 150   
 2: Φ16 150 



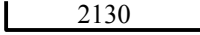
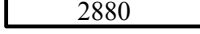
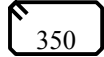
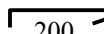

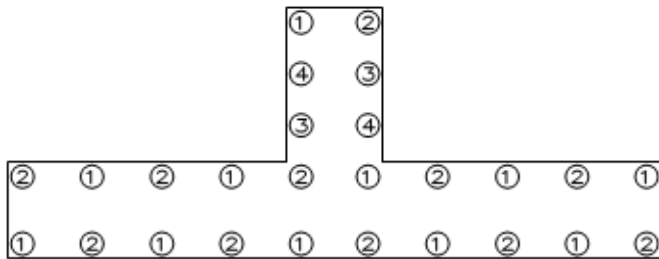
Φ8: 200x350  
 Φ8: L200

1GBZ7<13>	Φ16	150 	2250	4*13	52	184.86	下插920
	Φ16	150 	3000	4*13	52	246.48	同上
	Φ8	200 	1240	5*13	65	31.84	
	Φ8		360	6*13	78	11.09	



1: Φ18 150   
 Φ8: 200x600



2: Φ18 150   
 Φ8: 200x1650

3: Φ16 150   
 Φ8: L200

4: Φ16 150 

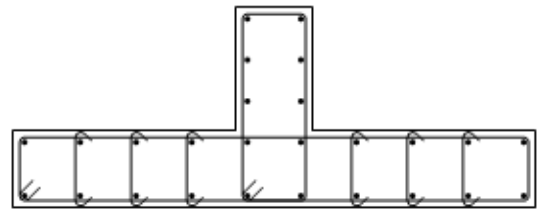
1GBZ8 Φ8@150

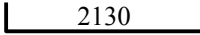
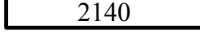
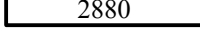
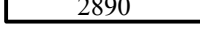
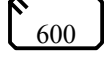
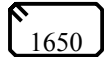

1GBZ8	Φ16	150 	2250	2	2	7.11	下插920
	Φ18	150 	2250	11	11	49.50	同上
	Φ16	150 	3000	2	2	9.48	同上
	Φ18	150 	3000	11	11	66.00	同上
	Φ8	200 	1740	5	5	3.44	
	Φ8	200 	3840	5	5	7.58	
	Φ8		360	18	18	2.56	

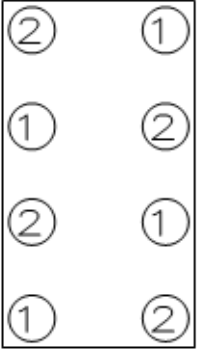
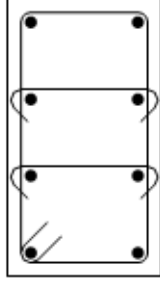
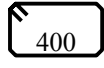
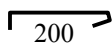
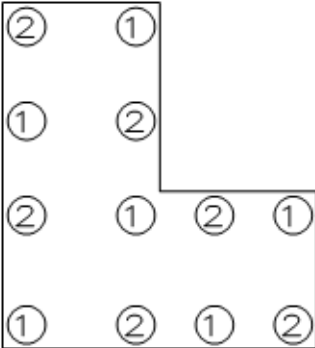
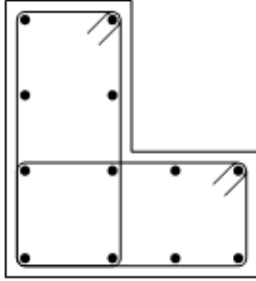
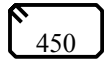
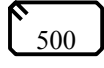
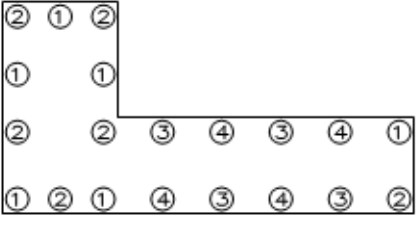
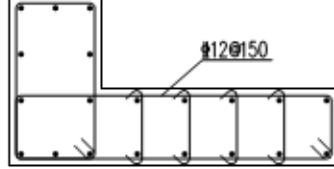
构件名称	级直径	钢筋简图	下料 (mm)	根件 数*数	总 根数	重量 (kg)	备注
		 <p>1GBZ9&lt;4&gt; <math>\Phi 8@150</math></p> <p>1: <math>\Phi 16</math> 150 <math>\lrcorner</math> 2880 2: <math>\Phi 16</math> 150 <math>\lrcorner</math> 2130</p>  <p><math>\Phi 8</math>: 200x400 <math>\Phi 8</math>: L200</p>					
1GBZ9<4>	$\Phi 16$	150 $\lrcorner$ 2130	2250	4*4	16	56.88	下插920
	$\Phi 16$	150 $\lrcorner$ 2880	3000	4*4	16	75.84	同上
	$\Phi 8$	200 	1340	5*4	20	10.59	
	$\Phi 8$		360	6*4	24	3.41	
		 <p>1GBZ10&lt;2&gt; <math>\Phi 8@150</math></p> <p>1: <math>\Phi 16</math> 150 <math>\lrcorner</math> 2880 2: <math>\Phi 16</math> 150 <math>\lrcorner</math> 2130</p>  <p><math>\Phi 8</math>: 200x450 <math>\Phi 8</math>: 200x500</p>					
1GBZ10<2>	$\Phi 16$	150 $\lrcorner$ 2130	2250	6*2	12	42.66	下插920
	$\Phi 16$	150 $\lrcorner$ 2880	3000	6*2	12	56.88	同上
	$\Phi 8$	200 	1440	5*2	10	5.69	
	$\Phi 8$	200 	1540	5*2	10	6.08	
		 <p>1GBZ11&lt;2&gt; <math>\Phi 8@150</math></p> <p>1: <math>\Phi 18</math> 150 <math>\lrcorner</math> 2890 2: <math>\Phi 18</math> 150 <math>\lrcorner</math> 2140 3: <math>\Phi 16</math> 150 <math>\lrcorner</math> 2880 4: <math>\Phi 16</math> 150 <math>\lrcorner</math> 2130</p>  <p><math>\Phi 12</math>: 200x1020 <math>\Phi 8</math>: 250x500 <math>\Phi 8</math>: L200</p>					
1GBZ11<2>	$\Phi 16$	150 $\lrcorner$ 2130	2250	4*2	8	28.44	下插920
	$\Phi 18$	150 $\lrcorner$ 2140	2250	6*2	12	54.00	同上

构件名称	级直别径	钢筋简图	下料 (mm)	根件 数*数	总 根数	重量 (kg)	备 注
	Φ16	150	3000	4*2	8	37.92	同上
	Φ18	150	3000	6*2	12	72.00	同上
	Φ12	200	2660	5*2	10	23.62	
	Φ8	250	1640	5*2	10	6.48	
	Φ8		360	12*2	24	3.41	

1GBZ12 Φ8@150

Φ8: 200x500  
Φ8: 250x800

1: Φ18 150   
 2: Φ16 150   
 3: Φ18 150   
 4: Φ16 150

1GBZ12	Φ16	150	2250	3	3	10.67	下插920
	Φ18	150	2250	6	6	27.00	同上
	Φ16	150	3000	3	3	14.22	同上
	Φ18	150	3000	6	6	36.00	同上
	Φ8	200	1540	5	5	3.04	
	Φ8	250	2240	5	5	4.42	

1GBZ13 Φ8@150

Φ8: 200x490  
Φ8: 250x800

1: Φ18 150   
 2: Φ16 150   
 3: Φ18 150   
 4: Φ16 150

1GBZ13	Φ16	150	2250	3	3	10.67	下插920
	Φ18	150	2250	6	6	27.00	同上
	Φ16	150	3000	3	3	14.22	同上
	Φ18	150	3000	6	6	36.00	同上



构件名称	级直径	钢筋简图	下料 (mm)	根件 数*数	总 根数	重量 (kg)	备注
	Φ8	200	1520	5	5	3.00	
	Φ8	250	2240	5	5	4.42	
<div style="display: flex; justify-content: space-between;"> <div style="border: 1px solid black; padding: 5px;"> </div> <div style="text-align: center;"> <p>1GBZ14&lt;12&gt; Φ8@150</p> </div> <div style="text-align: right;"> <p>Φ8: 250x350 Φ8: L250</p> </div> </div> <div style="margin-top: 10px;"> <p>1: Φ16 150 </p> <p>2: Φ16 150 </p> </div>							
1GBZ14<8>	Φ16	150	2250	4*8	32	113.76	下插920
	Φ16	150	3000	4*8	32	151.68	同上
	Φ8	250	1340	5*8	40	21.17	
	Φ8		410	3*8	24	3.89	
<div style="display: flex; justify-content: space-between;"> <div style="border: 1px solid black; padding: 5px;"> </div> <div style="text-align: center;"> <p>1GBZ14&lt;4&gt; Φ8@150</p> </div> <div style="text-align: right;"> <p>Φ8: 250x350 Φ8: L250</p> </div> </div> <div style="margin-top: 10px;"> <p>1: Φ16 150 </p> </div>							
1GBZ14<4> 用于A轴	Φ16	150	5100	8*4	32	257.86	下插920
	Φ8	250	1340	5*4	20	10.59	
	Φ8		410	3*4	12	1.94	
<div style="display: flex; justify-content: space-between;"> <div style="border: 1px solid black; padding: 5px;"> </div> <div style="text-align: center;"> <p>1GBZ15 Φ8@150</p> </div> <div style="text-align: right;"> <p>Φ8: 210x250 Φ8: 250x550</p> </div> </div> <div style="margin-top: 10px;"> <p>1: Φ18 150 </p> <p>2: Φ16 150 </p> <p>3: Φ16 150 </p> <p>4: Φ18 150 </p> </div>							
1GBZ15	Φ16	150	2250	2	2	7.11	下插920
	Φ18	150	2250	3	3	13.50	同上

构件名称	级直径	钢筋简图	下料 (mm)	根件 数*数	总 根数	重量 (kg)	备注
	Φ16	150	3000	2	2	9.48	同上
	Φ18	150	3000	3	3	18.00	同上
	Φ8	210	1060	3	3	1.26	
	Φ8	250	1740	5	5	3.44	

① ② ①

② ②

① ② ①

1GBZ16<2> Φ8@150

1: Φ18 150

2: Φ18 150

Φ8: 250x400

Φ8: L250

1GBZ16<2>	Φ18	150	2250	4*2	8	36.00	下插920
	Φ18	150	3000	4*2	8	48.00	同上
	Φ8	250	1440	5*2	10	5.69	
	Φ8		410	3*2	6	0.97	

② ① ②

① ①

② ① ② ②

① ② ① ①

② ②

① ② ①

1GBZ17<2> Φ8@150

1: Φ16 150

2: Φ16 150

Φ8: 150x550

Φ8: 250x750

1GBZ17<2>	Φ16	150	2250	9*2	18	63.99	下插920
	Φ16	150	3000	9*2	18	85.32	同上
	Φ8	150	1540	5*2	10	6.08	
	Φ8	250	2140	5*2	10	8.45	

构件名称	级直径	钢筋简图	下料 (mm)	根件 数*数	总 根数	重量 (kg)	备注
		<p>1GBZ18 <math>\Phi 8@150</math></p> <p>1: <math>\Phi 18</math> 150 <math>\overline{2890}</math>  2: <math>\Phi 18</math> 150 <math>\overline{2140}</math>  3: <math>\Phi 16</math> 150 <math>\overline{2130}</math></p> <p><math>\Phi 8</math>: 250x600  <math>\Phi 12</math>: 250x700  <math>\Phi 8</math>: L250</p>					
1GBZ18	$\Phi 16$	150 $\overline{2130}$	2250	2	2	7.11	下插920
	$\Phi 18$	150 $\overline{2140}$	2250	7	7	31.50	同上
	$\Phi 18$	150 $\overline{2890}$	3000	9	9	54.00	同上
	$\Phi 8$	250 $\overline{600}$	1840	5	5	3.63	
	$\Phi 12$	250 $\overline{700}$	2120	5	5	9.41	
	$\Phi 8$	$\overline{250}$	410	9	9	1.46	
		<p>1GBZ19 <math>\Phi 8@150</math></p> <p>1: <math>\Phi 18</math> 150 <math>\overline{2890}</math>  2: <math>\Phi 18</math> 150 <math>\overline{2140}</math></p> <p><math>\Phi 8</math>: 200x1050  <math>\Phi 8</math>: 250x500  <math>\Phi 8</math>: L200</p>					
1GBZ19	$\Phi 18$	150 $\overline{2140}$	2250	9	9	40.50	下插920
	$\Phi 18$	150 $\overline{2890}$	3000	9	9	54.00	同上
	$\Phi 8$	200 $\overline{1050}$	2640	5	5	5.21	
	$\Phi 8$	250 $\overline{500}$	1640	5	5	3.24	
	$\Phi 8$	$\overline{200}$	360	9	9	1.28	
		<p>1GBZ20&lt;3&gt; <math>\Phi 8@150</math></p> <p>1: <math>\Phi 16</math> 150 <math>\overline{2880}</math>  2: <math>\Phi 16</math> 150 <math>\overline{2130}</math></p> <p><math>\Phi 8</math>: 150x350  <math>\Phi 8</math>: L150</p>					
1GBZ20<3>	$\Phi 16$	150 $\overline{2130}$	2250	4*3	12	42.66	下插920
	$\Phi 16$	150 $\overline{2880}$	3000	4*3	12	56.88	同上
	$\Phi 8$	150 $\overline{350}$	1140	5*3	15	6.75	

构件名称	级直别径	钢筋简图	下料 (mm)	根件 数*数	总 根数	重量 (kg)	备 注
	Φ8		310	6*3	18	2.20	
<div style="display: flex; justify-content: space-between; align-items: flex-start;"> <div style="text-align: center;"> </div> <div style="text-align: center;"> <p>1GBZ21 Φ8@150</p> </div> <div style="text-align: right;"> <p>Φ8: 450x450 Φ8: 150x850 Φ8: 200x850 Φ8: L200 Φ8: L450</p> </div> </div> <p style="margin-top: 10px;"> 1: Φ18 150┐ 4710  2: Φ18 150┐ 3960  3: Φ20 150┐ 4710  4: Φ20 150┐ 3960 </p>							
1GBZ21	Φ18	150┐ 3960	4070	4	4	32.56	下插2740
	Φ20	150┐ 3960	4070	6	6	60.32	同上
	Φ18	150┐ 4710	4820	4	4	38.56	同上
	Φ20	150┐ 4710	4820	6	6	71.43	同上
	Φ8	450┐ 450	1940	15	15	11.49	
	Φ8	150┐ 850	2140	15	15	12.68	
	Φ8	200┐ 850	2240	15	15	13.27	
	Φ8	┐ 200	360	13	13	1.85	
	Φ8	┐ 450	610	26	26	6.26	
<div style="display: flex; justify-content: space-between; align-items: flex-start;"> <div style="text-align: center;"> </div> <div style="text-align: center;"> <p>1GBZ22 Φ8@150</p> </div> <div style="text-align: right;"> <p>Φ12: 150x650 Φ8: 150x750 Φ8: L150</p> </div> </div> <p style="margin-top: 10px;"> 1: Φ16 150┐ 4700  2: Φ16 150┐ 3950 </p>							
1GBZ22	Φ16	150┐ 3950	4070	9	9	57.88	下插2740
	Φ16	150┐ 4700	4820	9	9	68.54	同上
	Φ12	150┐ 650	1820	15	15	24.24	
	Φ8	150┐ 750	1940	15	15	11.49	
	Φ8	┐ 150	310	26	26	3.18	

审核:

翻样: 钟祥祯13653434429

第 11 页,共43页

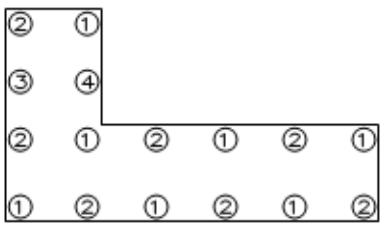
构件名称	级直别径	钢筋简图	下料 (mm)	根件 数*数	总 根数	重量 (kg)	备注
			1: $\Phi 18$ 150 $\sqrt{2890}$ 2: $\Phi 18$ 150 $\sqrt{2140}$ 3: $\Phi 16$ 150 $\sqrt{2880}$ 4: $\Phi 16$ 150 $\sqrt{2130}$				1GBZ23<2> $\Phi 8@150$ $\Phi 8$ : 200x500 $\Phi 12$ : 200x920 $\Phi 8$ : L200

1GBZ23<2>	$\Phi 16$	150 $\sqrt{2130}$	2250	1*2	2	7.11	下插920
	$\Phi 18$	150 $\sqrt{2140}$	2250	7*2	14	63.00	同上
	$\Phi 16$	150 $\sqrt{2880}$	3000	1*2	2	9.48	同上
	$\Phi 18$	150 $\sqrt{2890}$	3000	7*2	14	84.00	同上
	$\Phi 8$	200 $\sqrt{500}$	1540	5*2	10	6.08	
	$\Phi 12$	200 $\sqrt{920}$	2460	5*2	10	21.84	
	$\Phi 8$	$\sqrt{200}$	360	9*2	18	2.56	

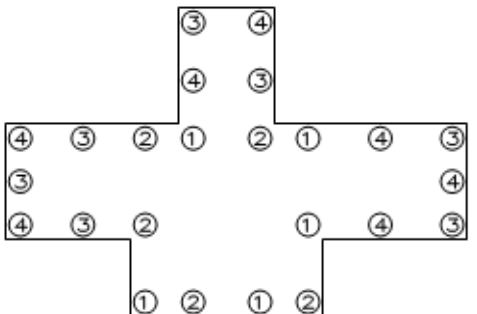
			1: $\Phi 20$ 150 $\sqrt{2890}$ 2: $\Phi 20$ 150 $\sqrt{2140}$ 3: $\Phi 18$ 150 $\sqrt{2890}$ 4: $\Phi 18$ 150 $\sqrt{2140}$				1GBZ24 $\Phi 8@150$ $\Phi 8$ : 200x750 $\Phi 8$ : 450x450 $\Phi 8$ : 250x1150 $\Phi 8$ : L250 $\Phi 8$ : L1150
--	--	---	--	--	--	--	---



1GBZ24	$\Phi 20$	150 $\sqrt{2140}$	2250	5	5	27.79	下插920
	$\Phi 18$	150 $\sqrt{2140}$	2250	7	7	31.50	同上
	$\Phi 20$	150 $\sqrt{2890}$	3000	5	5	37.05	同上
	$\Phi 18$	150 $\sqrt{2890}$	3000	7	7	42.00	同上
	$\Phi 8$	200 $\sqrt{750}$	2040	5	5	4.03	
	$\Phi 8$	450 $\sqrt{450}$	1940	5	5	3.83	
	$\Phi 8$	250 $\sqrt{1150}$	2940	5	5	5.81	
	$\Phi 8$	$\sqrt{250}$	410	6	6	0.97	

构件名称	级直径	钢筋简图	下料 (mm)	根件 数*数	总 根数	重量 (kg)	备注
	Φ8		1310	3	3	1.55	
<div style="display: flex; justify-content: space-between; align-items: flex-start;"> <div style="text-align: center;"> <p>1: Φ18 150   2890 2: Φ18 150   2140</p> </div> <div style="text-align: center;"> <p>1GBZ25&lt;2&gt; Φ8@150</p> </div> <div style="text-align: right;"> <p>Φ8: 250x300 Φ8: 200x500 Φ8: 200x900 Φ8: 200x1200 Φ8: L200</p> </div> </div>							
1GBZ25<2>	Φ18	150	2250	15*2	30	135.00	下插920
	Φ18	150	3000	15*2	30	180.00	同上
	Φ8	250	1240	5*2	10	4.90	
	Φ8	200	1540	5*2	10	6.08	
	Φ8	200	2340	5*2	10	9.24	
	Φ8	200	2940	5*2	10	11.61	
	Φ8		360	15*2	30	4.27	
<div style="display: flex; justify-content: space-between; align-items: flex-start;"> <div style="text-align: center;"> <p>1: Φ16 150   4700 2: Φ16 150   3950</p> </div> <div style="text-align: center;"> <p>1GBZ26 Φ8@150 Φ12@150</p> </div> <div style="text-align: right;"> <p>Φ12: 150x700 Φ8: 200x600 Φ8: L150 Φ8: L200</p> </div> </div>							
1GBZ26	Φ16	150	4070	8	8	51.44	下插2740
	Φ16	150	4820	8	8	60.92	同上
	Φ12	150	1920	15	15	25.57	
	Φ8	200	1740	15	15	10.31	

构件名称	级直别径	钢筋简图	下料 (mm)	根件 数*数	总 根数	重量 (kg)	备注
	Φ8		310	26	26	3.18	
	Φ8		360	26	26	3.70	
<div style="display: flex; justify-content: space-between;"> <div style="width: 30%;"> <p>1: Φ18 150   4710 2: Φ18 150   3960 3: Φ20 150   4710 4: Φ20 150   3960</p> </div> <div style="width: 30%; text-align: center;"> <p>1GBZ27 Φ8@150</p> </div> <div style="width: 30%; text-align: right;"> <p>Φ8: 450x450 Φ8: 200x750 Φ8: L450</p> </div> </div>							
1GBZ27	Φ18	150	4070	4	4	32.56	下插2740
	Φ20	150	4070	6	6	60.32	同上
	Φ18	150	4820	4	4	38.56	同上
	Φ20	150	4820	6	6	71.43	同上
	Φ8	450	1940	15	15	11.49	
	Φ8	200	2040	30	30	24.17	
	Φ8		610	26	26	6.26	
<div style="display: flex; justify-content: space-between;"> <div style="width: 30%;"> <p>1: Φ18 150   2890 2: Φ18 150   2140 3: Φ20 150   2140 4: Φ20 150   2890</p> </div> <div style="width: 30%; text-align: center;"> <p>1GBZ28&lt;2&gt; Φ8@150</p> </div> <div style="width: 30%; text-align: right;"> <p>Φ8: 180x200 Φ8: 200x500 Φ12: 200x600 Φ8: 200x1150 Φ8: L200</p> </div> </div>							
1GBZ28<2>	Φ18	150	2250	7*2	14	63.00	下插920
	Φ20	150	2250	5*2	10	55.58	同上
	Φ18	150	3000	7*2	14	84.00	同上
	Φ20	150	3000	5*2	10	74.10	同上

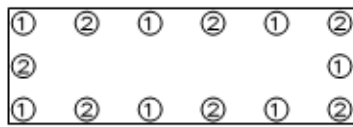
构件名称	级直别径	钢筋简图	下料 (mm)	根件 数*数	总 根数	重量 (kg)	备注
	Φ8	180 	900	3*2	6	2.13	
	Φ8	200 	1540	5*2	10	6.08	
	Φ12	200 	1820	5*2	10	16.16	
	Φ8	200 	2840	5*2	10	11.22	
	Φ8		360	12*2	24	3.41	





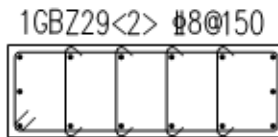

1: Φ20 150   
 2: Φ20 150 

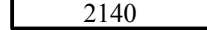
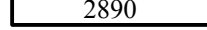
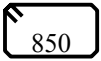
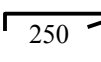

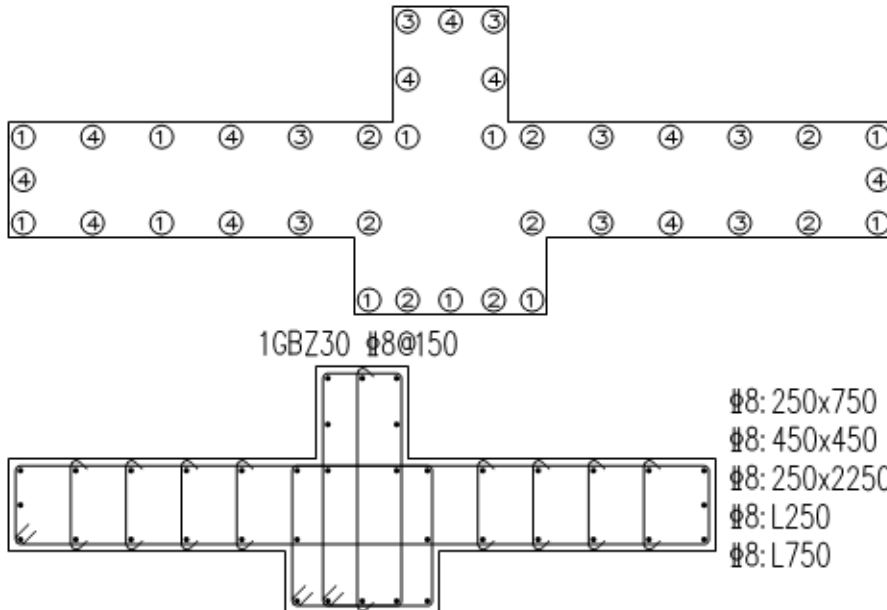
Φ8: 250x850  
 Φ8: L250

1GBZ29<2>	Φ20	150 	2250	7*2	14	77.81	下插920
	Φ20	150 	3000	7*2	14	103.74	同上
	Φ8	250 	2340	5*2	10	9.24	
	Φ8		410	12*2	24	3.89	

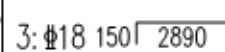

1: Φ20 150   
 2: Φ20 150   
 3: Φ18 150   
 4: Φ18 150 

1GBZ30 Φ8@150

Φ8: 250x750  
 Φ8: 450x450  
 Φ8: 250x2250  
 Φ8: L250  
 Φ8: L750

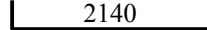
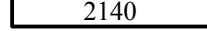
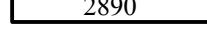
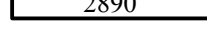
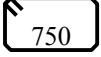
1GBZ30	Φ20	150 	2250	8	8	44.46	下插920
	Φ18	150 	2250	11	11	49.50	同上
	Φ20	150 	3000	11	11	81.51	同上
	Φ18	150 	3000	8	8	48.00	同上
	Φ8	250 	2140	5	5	4.23	



构件名称	级直别径	钢筋简图	下料 (mm)	根件 数*数	总 根数	重量 (kg)	备注
	Φ8	450	1940	5	5	3.83	
	Φ8	250	5140	5	5	10.15	
	Φ8		410	24	24	3.89	
	Φ8		910	3	3	1.08	

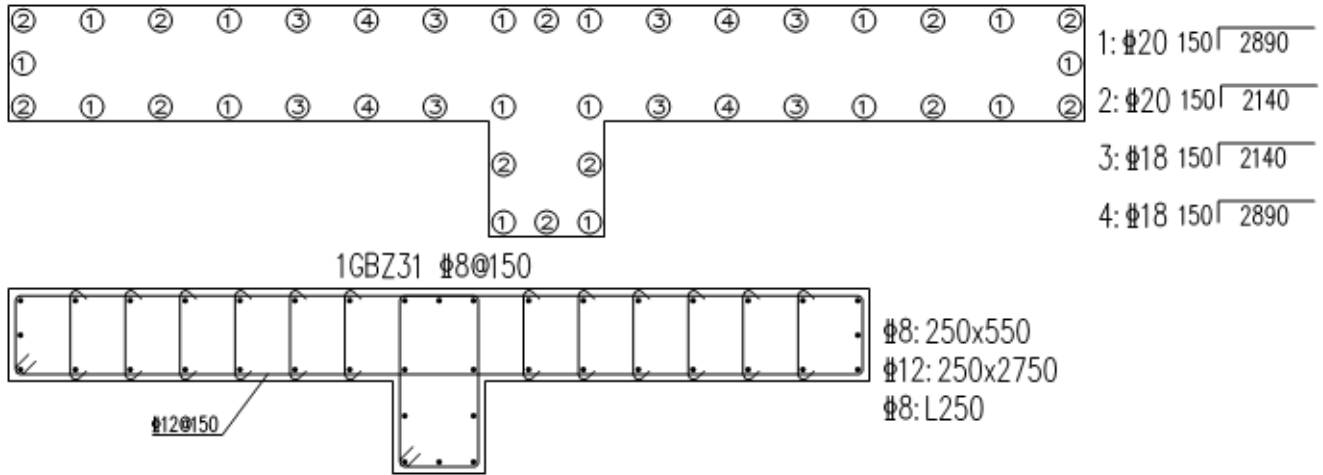

1GBZ31	Φ20	150	2140	2250	12	12	66.69	下插920
	Φ18	150	2140	2250	8	8	36.00	同上
	Φ20	150	2890	3000	16	16	118.56	同上
	Φ18	150	2890	3000	4	4	24.00	同上
	Φ8	250	550	1740	5	5	3.44	
	Φ12	250	2750	6220	5	5	27.62	
	Φ8		250	410	36	36	5.83	

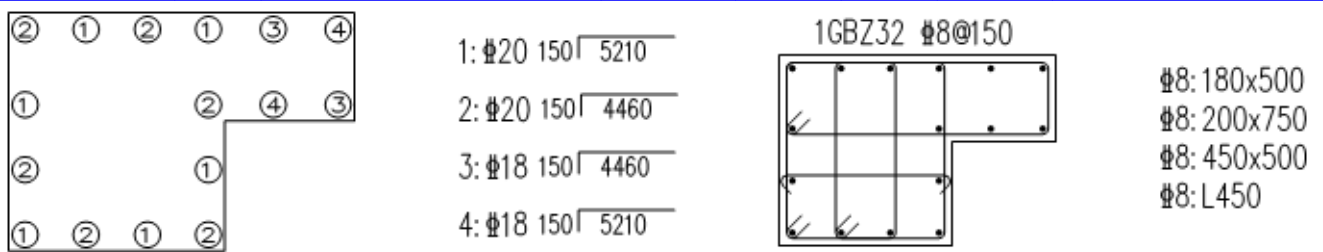

1GBZ32	Φ20	150	4460	4570	6	6	67.73	下插3240
	Φ18	150	4460	4570	2	2	18.28	同上
	Φ20	150	5210	5320	6	6	78.84	同上

构件名称	级直别径	钢筋简图	下料 (mm)	根件 数*数	总 根数	重量 (kg)	备注
	Φ18	150	5320	2	2	21.28	同上
	Φ8	180	1500	15	15	8.89	
	Φ8	200	2040	18	18	14.50	
	Φ8	450	2040	18	18	14.50	
	Φ8		610	15	15	3.61	

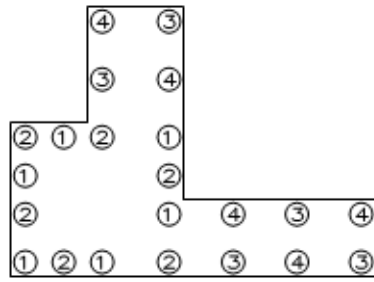

- 1: Φ18 150
- 2: Φ18 150
- 3: Φ16 150
- 4: Φ16 150

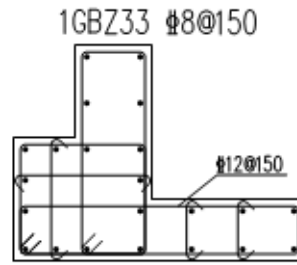

- Φ8: 200x650  
Φ8: 350x400  
Φ12: 150x900  
Φ8: L150  
Φ8: L350  
Φ8: L400

1GBZ33	Φ16	150	4570	5	5	36.10	下插3240
	Φ18	150	4570	6	6	54.84	同上
	Φ16	150	5320	5	5	42.03	同上
	Φ18	150	5320	6	6	63.84	同上
	Φ8	200	1840	18	18	13.08	
	Φ8	350	1640	18	18	11.66	
	Φ12	150	2320	18	18	37.08	
	Φ8		310	30	30	3.67	
	Φ8		510	15	15	3.02	
	Φ8		560	15	15	3.32	

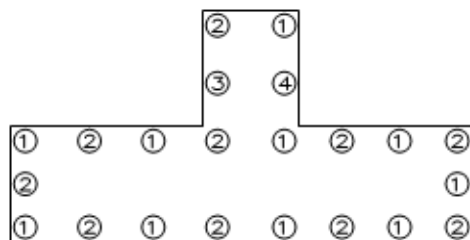



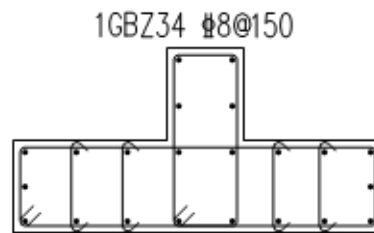



- 1: Φ18 150
- 2: Φ18 150
- 3: Φ16 150
- 4: Φ16 150

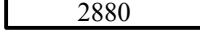
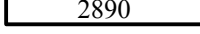
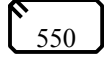
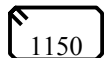
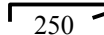
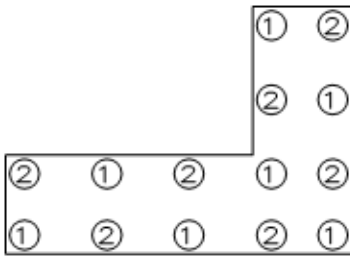

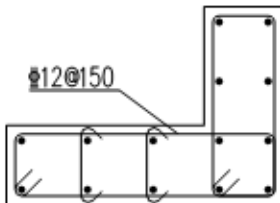
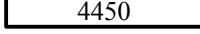
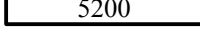
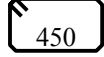
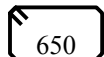
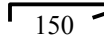
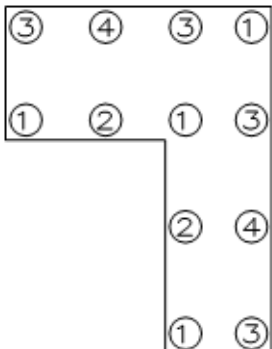
- Φ8: 200x550  
Φ8: 250x1150  
Φ8: L250

1GBZ34	Φ16	150	2250	1	1	3.56	下插920
	Φ18	150	2250	10	10	45.00	同上

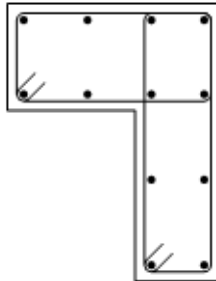
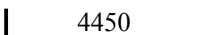
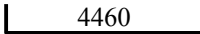
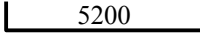
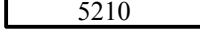
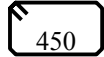
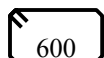
构件名称	级直别径	钢筋简图	下料 (mm)	根件 数*数	总 根数	重量 (kg)	备 注
	Φ16	150 	3000	1	1	4.74	同上
	Φ18	150 	3000	10	10	60.00	同上
	Φ8	200 	1640	5	5	3.24	
	Φ8	250 	2940	5	5	5.81	
	Φ8		410	12	12	1.94	
<div style="display: flex; justify-content: space-between; align-items: flex-start;"> <div style="text-align: center;">  <p>1: Φ16 150 </p> <p>2: Φ16 150 </p> </div> <div style="text-align: center;"> <p>1GBZ35 Φ8@150</p>  </div> <div style="text-align: right;"> <p>Φ8: 150x450 Φ12: 150x650 Φ8: L150</p> </div> </div>							
1GBZ35	Φ16	150 	4570	7	7	50.54	下插3240
	Φ16	150 	5320	7	7	58.84	同上
	Φ8	150 	1340	18	18	9.53	
	Φ12	150 	1820	18	18	29.09	
	Φ8		310	30	30	3.67	
<div style="display: flex; justify-content: space-between; align-items: flex-start;"> <div style="text-align: center;">  <p>1: Φ18 150 </p> <p>2: Φ16 150 </p> <p>3: Φ18 150 </p> <p>4: Φ16 150 </p> </div> <div style="text-align: center;"> <p>1GBZ36 Φ8@150</p>  </div> <div style="text-align: right;"> <p>Φ8: 200x450 Φ8: 150x600</p> </div> </div>							
1GBZ36	Φ16	150 	4570	2	2	14.44	下插3240
	Φ18	150 	4570	4	4	36.56	同上
	Φ16	150 	5320	2	2	16.81	同上
	Φ18	150 	5320	4	4	42.56	同上
	Φ8	200 	1440	18	18	10.24	
	Φ8	150 	1640	18	18	11.66	

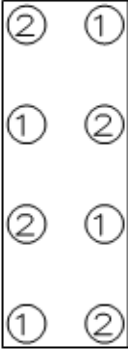
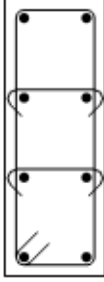
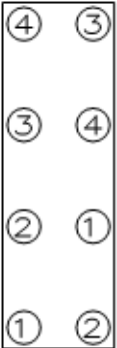
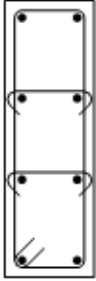
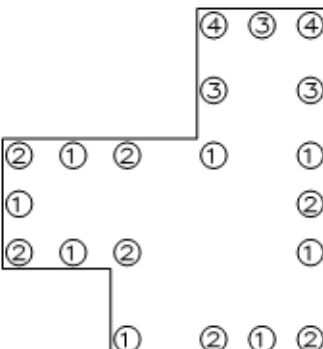
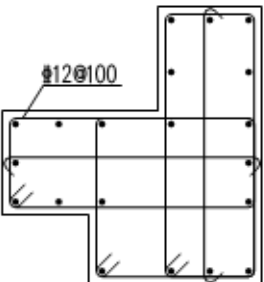
构件名称	级直径	钢筋简图	下料 (mm)	根件 数*数	总 根数	重量 (kg)	备 注
		 <p>1GBZ37 <math>\Phi 8@150</math></p> <p>1: <math>\Phi 16</math> 150 <math>\sqrt{2880}</math> 2: <math>\Phi 16</math> 150 <math>\sqrt{2130}</math></p>  <p><math>\Phi 8: 150 \times 500</math> <math>\Phi 8: L150</math></p>					
1GBZ37	$\Phi 16$	150 $\sqrt{2130}$	2250	4	4	14.22	下插920
	$\Phi 16$	150 $\sqrt{2880}$	3000	4	4	18.96	同上
	$\Phi 8$	150 $\sqrt{500}$	1440	5	5	2.84	
	$\Phi 8$	$\sqrt{150}$	310	6	6	0.73	
		 <p>1GBZ38 <math>\Phi 8@150</math></p> <p>1: <math>\Phi 16</math> 150 <math>\sqrt{2880}</math> 2: <math>\Phi 16</math> 150 <math>\sqrt{2130}</math> 3: <math>\Phi 16</math> 150 <math>\sqrt{5200}</math> 4: <math>\Phi 16</math> 150 <math>\sqrt{4450}</math></p>  <p><math>\Phi 8: 150 \times 570</math> <math>\Phi 8: L150</math></p>					
1GBZ38	$\Phi 16$	150 $\sqrt{2130}$	2250	2	2	7.11	下插920
	$\Phi 16$	150 $\sqrt{2880}$	3000	2	2	9.48	同上
	$\Phi 16$	150 $\sqrt{4450}$	4570	2	2	14.44	下插3240
	$\Phi 16$	150 $\sqrt{5200}$	5320	2	2	16.81	同上
	$\Phi 8$	150 $\sqrt{570}$	1580	5	5	3.12	
	$\Phi 8$	$\sqrt{150}$	310	6	6	0.73	
		 <p>1GBZ39 <math>\Phi 8@100</math></p> <p>1: <math>\Phi 20</math> 150 <math>\sqrt{2890}</math> 2: <math>\Phi 20</math> 150 <math>\sqrt{2140}</math> 3: <math>\Phi 18</math> 150 <math>\sqrt{2140}</math> 4: <math>\Phi 18</math> 150 <math>\sqrt{2890}</math></p>  <p><math>\Phi 12: 250 \times 700</math> <math>\Phi 8: 450 \times 450</math> <math>\Phi 8: 250 \times 750</math> <math>\Phi 8: L700</math> <math>\Phi 8: L750</math></p>					

构件名称	级直别径	钢筋简图	下料 (mm)	根件 数*数	总 根数	重量 (kg)	备注
1GBZ39	Φ20	150	2250	7	7	38.90	下插920
	Φ18	150	2250	3	3	13.50	同上
	Φ20	150	3000	8	8	59.28	同上
	Φ18	150	3000	2	2	12.00	同上
	Φ12	250	2120	5	5	9.41	
	Φ8	450	1940	5	5	3.83	
	Φ8	250	2140	5	5	4.23	
	Φ8		860	3	3	1.02	
	Φ8		910	3	3	1.08	

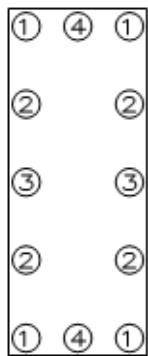

- 1: Φ18 150
- 2: Φ16 150
- 3: Φ16 150
- 4: Φ18 150

1GBZ40 Φ8@150

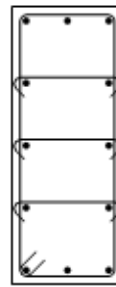

Φ8: 250x700  
Φ8: L250

1GBZ40	Φ16	150	4070	4	4	25.72	下插2740
	Φ18	150	4070	2	2	16.28	同上
	Φ16	150	4820	2	2	15.23	同上
	Φ18	150	4820	4	4	38.56	同上
	Φ8	250	2040	15	15	12.09	
	Φ8		410	26	26	4.21	

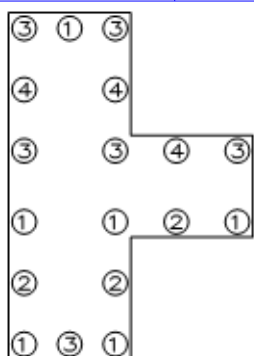

- 1: Φ18 150
- 2: Φ16 150
- 3: Φ18 150
- 4: Φ16 150

1GBZ41 Φ8@150

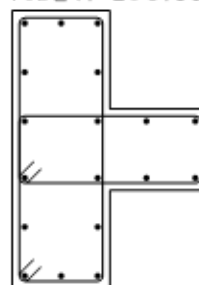

Φ8: 200x550  
Φ8: 250x800

构件名称	级直径	钢筋简图	下料 (mm)	根件 数*数	总 根数	重量 (kg)	备注
1GBZ41	Φ16	150	4070	3	3	19.29	下插2740
	Φ18	150	4070	6	6	48.84	同上
	Φ16	150	4820	3	3	22.85	同上
	Φ18	150	4820	6	6	57.84	同上
	Φ8	200	1640	15	15	9.72	
	Φ8	250	2240	15	15	13.27	

1GBZ42 Φ8@150

Φ12: 200x700  
Φ8: 250x600  
Φ8: L200  
Φ8: L250

1: Φ18 150

2: Φ18 150

3: Φ16 150

4: Φ16 150

1GBZ42	Φ16	150	2250	2	2	7.11	下插920
	Φ18	150	2250	6	6	27.00	同上
	Φ16	150	3000	2	2	9.48	同上
	Φ18	150	3000	6	6	36.00	同上
	Φ12	200	2020	5	5	8.97	
	Φ8	250	1840	5	5	3.63	
	Φ8		360	6	6	0.85	
	Φ8		410	3	3	0.49	

1GBZ43 Φ8@150

Φ8: 180x600  
Φ8: 200x1100  
Φ8: 450x600  
Φ8: L200  
Φ8: L450

1: Φ20 150

2: Φ20 150

3: Φ18 150

4: Φ18 150

1GBZ43	Φ20	150	2250	7	7	38.90	下插920
	Φ18	150	2250	3	3	13.50	同上

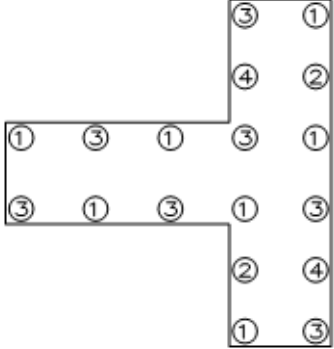

构件名称	级直别径	钢筋简图	下料(mm)	根件数*数	总根数	重量(kg)	备注
	Φ20	150 	3000	7	7	51.87	同上
	Φ18	150 	3000	3	3	18.00	同上
	Φ8	180 	1700	5	5	3.36	
	Φ8	200 	2740	5	5	5.41	
	Φ8	450 	2240	5	5	4.42	
	Φ8		360	9	9	1.28	
	Φ8		610	3	3	0.72	

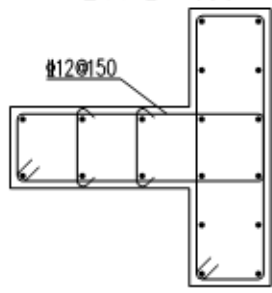

1GBZ44 Φ8@150

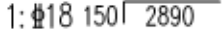
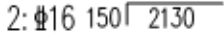

Φ12: 200x750  
Φ8: 200x800  
Φ8: L200

1: Φ18 150   
 2: Φ16 150   
 3: Φ18 150   
 4: Φ16 150 

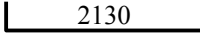
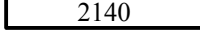
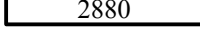
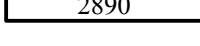
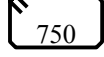
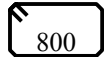
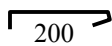

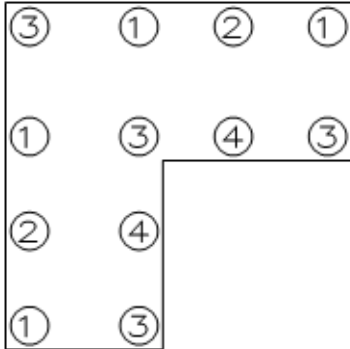

1GBZ44	Φ16	150 	2250	2	2	7.11	下插920
	Φ18	150 	2250	7	7	31.50	同上
	Φ16	150 	3000	2	2	9.48	同上
	Φ18	150 	3000	7	7	42.00	同上
	Φ12	200 	2120	5	5	9.41	
	Φ8	200 	2140	5	5	4.23	
	Φ8		360	6	6	0.85	

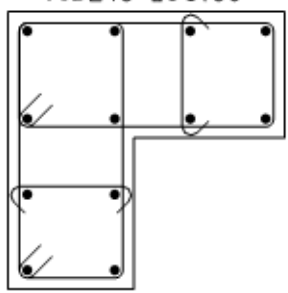

1GBZ45 Φ8@150

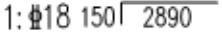

Φ8: 200x500  
Φ8: L200

1: Φ18 150   
 2: Φ16 150   
 3: Φ18 150   
 4: Φ16 150 

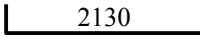
1GBZ45	Φ16	150 	2250	2	2	7.11	下插920
--------	-----	---	------	---	---	------	-------

构件名称	级直别径	钢筋简图	下料 (mm)	根件 数*数	总 根数	重量 (kg)	备 注
	Φ18	150  2140	2250	4	4	18.00	同上
	Φ16	150  2880	3000	2	2	9.48	同上
	Φ18	150  2890	3000	4	4	24.00	同上
	Φ8	200  500	1540	10	10	6.08	
	Φ8	 200	360	6	6	0.85	

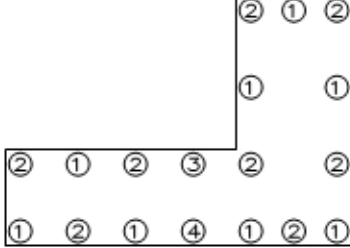

1GBZ46 Φ8@150

1: Φ18 150  2890



2: Φ18 150  2140

3: Φ16 150  2880

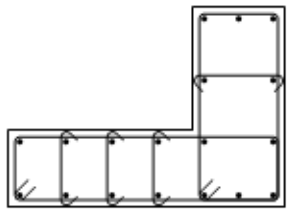
4: Φ16 150  2130



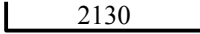
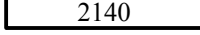
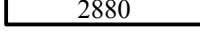
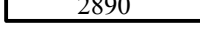
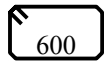
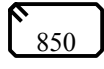

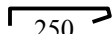
Φ8: 250x600  
Φ8: 200x850  
Φ8: L200  
Φ8: L250

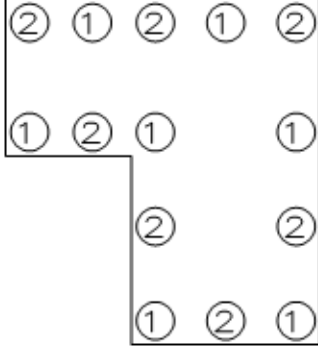
1GBZ46	Φ16	150  2130	2250	1	1	3.56	下插920
	Φ18	150  2140	2250	8	8	36.00	同上
	Φ16	150  2880	3000	1	1	4.74	同上
	Φ18	150  2890	3000	8	8	48.00	同上
	Φ8	250  600	1840	5	5	3.63	
	Φ8	200  850	2240	5	5	4.42	
	Φ8	 200	360	9	9	1.28	
	Φ8	 250	410	3	3	0.49	



1GBZ47 Φ8@150

1: Φ16 150  2880



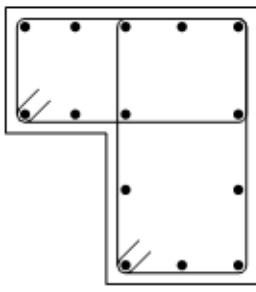

2: Φ16 150  2130

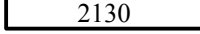
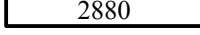
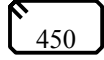



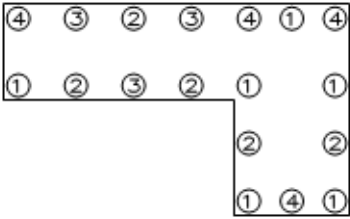
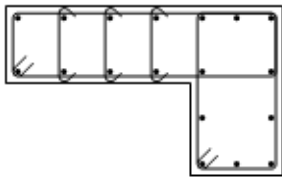
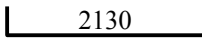
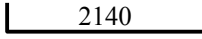
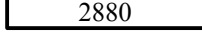
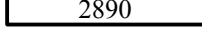

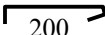
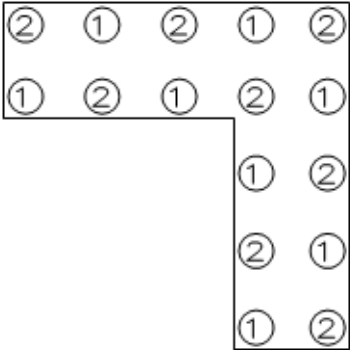
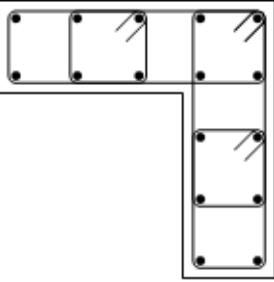
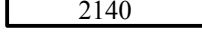
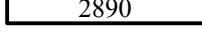

Φ8: 200x450  
Φ8: 250x500

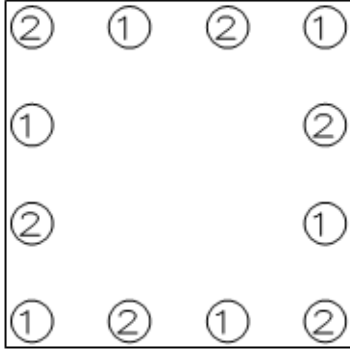
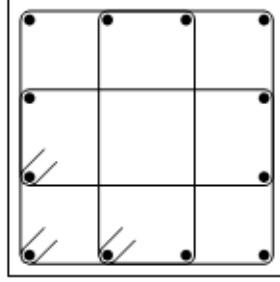
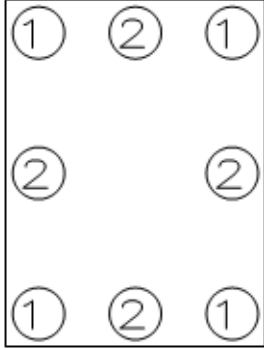
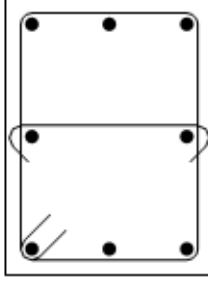
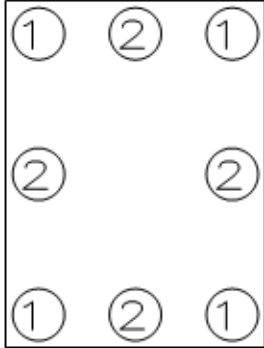
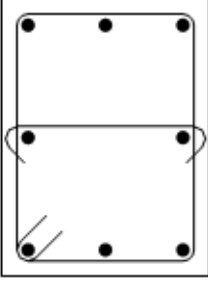
1GBZ47	Φ16	150  2130	2250	7	7	24.89	下插920
	Φ16	150  2880	3000	7	7	33.18	同上
	Φ8	200  450	1440	5	5	2.84	

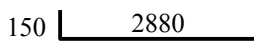

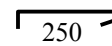
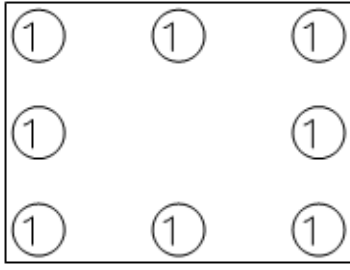
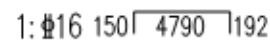
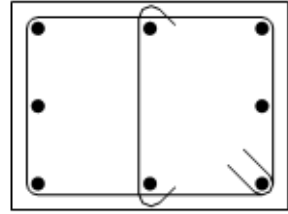
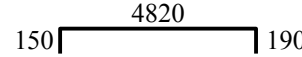
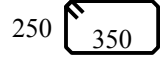
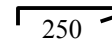
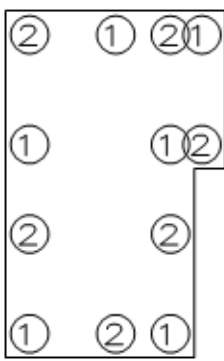
构件名称	级直别径	钢筋简图	下料 (mm)	根件 数*数	总 根数	重量 (kg)	备注
	Φ8	250 	1640	5	5	3.24	
<div style="display: flex; justify-content: space-between; align-items: flex-start;"> <div style="text-align: center;">  <p>1: Φ18 150   2890 2: Φ16 150   2130 3: Φ16 150   2880 4: Φ18 150   2140</p> </div> <div style="text-align: center;"> <p>1GBZ48 Φ8@150</p>  </div> <div style="text-align: right;"> <p>Φ8: 250x500 Φ8: 200x850 Φ8: L200</p> </div> </div>							
1GBZ48	Φ16	150 	2250	5	5	17.78	下插920
	Φ18	150 	2250	4	4	18.00	同上
	Φ16	150 	3000	3	3	14.22	同上
	Φ18	150 	3000	6	6	36.00	同上
	Φ8	250 	1640	5	5	3.24	
	Φ8	200 	2240	5	5	4.42	
	Φ8		360	9	9	1.28	
<div style="display: flex; justify-content: space-between; align-items: flex-start;"> <div style="text-align: center;">  <p>1: Φ18 150   2890 2: Φ18 150   2140</p> </div> <div style="text-align: center;"> <p>1KZ1&lt;2&gt; Φ10@100</p>  </div> <div style="text-align: right;"> <p>Φ10: 150x170 Φ10: 150x550</p> </div> </div>							
1KZ1<2>	Φ18	150 	2250	8*2	16	72.00	下插920
	Φ18	150 	3000	8*2	16	96.00	同上
	Φ10	150 	820	10*2	20	10.12	
	Φ10	150 	1580	10*2	20	19.50	

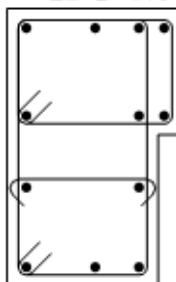
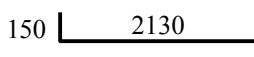
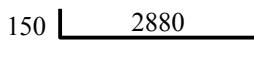
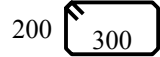
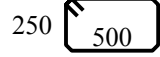
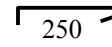
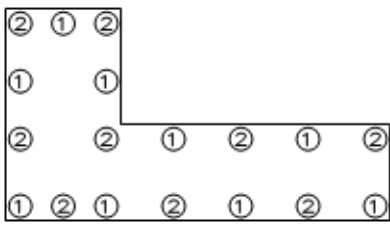
构件名称	级直 别径	钢筋简图	下料 (mm)	根件 数*数	总 根数	重量 (kg)	备注
<div style="display: flex; justify-content: space-between; align-items: flex-start;"> <div style="text-align: center;">  <p>1: <math>\Phi 18</math> 150 <math>\sqrt{2890}</math> 2: <math>\Phi 18</math> 150 <math>\sqrt{2140}</math></p> </div> <div style="text-align: center;"> <p>1KZ2&lt;4&gt; <math>\Phi 10@100</math></p>  <p><math>\Phi 10</math>: 180x450 <math>\Phi 10</math>: 450x450</p> </div> </div>							
1KZ2<4>	$\Phi 18$	150 $\sqrt{2140}$	2250	6*4	24	108.00	下插920
	$\Phi 18$	150 $\sqrt{2890}$	3000	6*4	24	144.00	同上
	$\Phi 10$	180 $\sqrt{450}$	1440	10*4	40	35.54	
	$\Phi 10$	450 $\sqrt{450}$	1980	5*4	20	24.43	
2/1~2/19轴 (东单元)							
<div style="display: flex; justify-content: space-between; align-items: flex-start;"> <div style="text-align: center;">  <p>1: <math>\Phi 14</math> 150 <math>\sqrt{2880}</math> 2: <math>\Phi 14</math> 150 <math>\sqrt{2130}</math></p> </div> <div style="text-align: center;"> <p>2AZ1&lt;2&gt; <math>\Phi 8@150</math></p>  <p><math>\Phi 8</math>: 250x350 <math>\Phi 8</math>: L250</p> </div> </div>							
2AZ1<2>	$\Phi 14$	150 $\sqrt{2130}$	2250	4*2	8	21.78	下插920
	$\Phi 14$	150 $\sqrt{2880}$	3000	4*2	8	29.04	同上
	$\Phi 8$	250 $\sqrt{350}$	1340	5*2	10	5.29	
	$\Phi 8$	$\sqrt{250}$	410	3*2	6	0.97	
<div style="display: flex; justify-content: space-between; align-items: flex-start;"> <div style="text-align: center;">  <p>1: <math>\Phi 16</math> 150 <math>\sqrt{2880}</math> 2: <math>\Phi 16</math> 150 <math>\sqrt{2130}</math></p> </div> <div style="text-align: center;"> <p>2GBZ1&lt;16&gt; <math>\Phi 8@150</math></p>  <p><math>\Phi 8</math>: 250x350 <math>\Phi 8</math>: L250</p> </div> </div>							
2GBZ1<14>	$\Phi 16$	150 $\sqrt{2130}$	2250	4*14	56	199.08	下插920

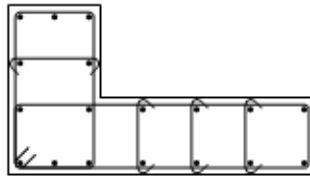
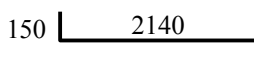
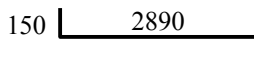
构件名称	级直径	钢筋简图	下料 (mm)	根件 数*数	总 根数	重量 (kg)	备注
	Φ16	150  2880	3000	4*14	56	265.44	同上
	Φ8	250  350	1340	5*14	70	37.05	
	Φ8	 250	410	3*14	42	6.80	
<div style="display: flex; justify-content: space-between; align-items: center;"> <div style="text-align: center;">  <p>1: Φ16 150  4790 192</p> </div> <div style="text-align: center;"> <p>2GBZ1&lt;2&gt; Φ8@150</p>  <p>Φ8: 250x350 Φ8: L250</p> </div> </div>							
2GBZ1<2>	Φ16	150  4820 190	5100	8*2	16	128.93	下插920
用于A轴	Φ8	250  350	1340	5*2	10	5.29	
	Φ8	 250	410	3*2	6	0.97	
<div style="display: flex; justify-content: space-between; align-items: center;"> <div style="text-align: center;">  <p>1: Φ16 150  2880 2: Φ16 150  2130</p> </div> <div style="text-align: center;"> <p>2GBZ2 Φ8@150</p>  <p>Φ8: 200x300 Φ8: 250x500 Φ8: L250</p> </div> </div>							
2GBZ2	Φ16	150  2130	2250	6	6	21.33	下插920
	Φ16	150  2880	3000	6	6	28.44	同上
	Φ8	200  300	1140	5	5	2.25	
	Φ8	250  500	1640	5	5	3.24	
	Φ8	 250	410	3	3	0.49	
<div style="display: flex; justify-content: space-between; align-items: center;"> <div style="text-align: center;">  <p>1: Φ18 150  2890 2: Φ18 150  2140</p> </div> <div style="text-align: center;"> <p>2GBZ3 Φ8@150</p>  <p>Φ8: 200x950 Φ8: 250x500 Φ8: L200 Φ8: L250</p> </div> </div>							
2GBZ3	Φ18	150  2140	2250	9	9	40.50	下插920
	Φ18	150  2890	3000	9	9	54.00	同上

构件名称	级直径	钢筋简图	下料 (mm)	根件 数*数	总 根数	重量 (kg)	备注
	Φ8	200	2440	5	5	4.82	
	Φ8	250	1640	5	5	3.24	
	Φ8		360	9	9	1.28	
	Φ8		410	3	3	0.49	

① ③ ④ ③

③ ①

① ③ ④ ③

② ④

① ③

1: Φ18 150 2890

2: Φ16 150 2130

3: Φ18 150 2140

4: Φ16 150 2880

2GBZ4<4> Φ8@150

Φ8: 200x550

Φ8: 250x500

2GBZ4<4>	Φ16	150  2130	2250	1*4	4	14.22	下插920
	Φ18	150  2140	2250	6*4	24	108.00	同上
	Φ16	150  2880	3000	3*4	12	56.88	同上
	Φ18	150  2890	3000	4*4	16	96.00	同上
	Φ8	200  550	1640	5*4	20	12.96	
	Φ8	250  500	1640	5*4	20	12.96	

② ①

① ②

② ①

① ②

1: Φ16 150 2880

2: Φ16 150 2130

2GBZ5<7> Φ8@150





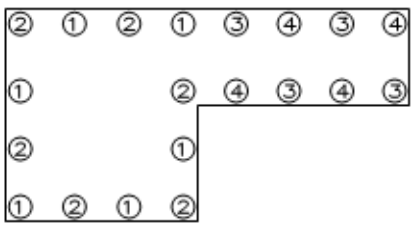
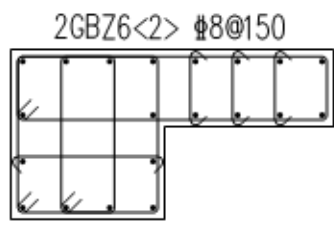
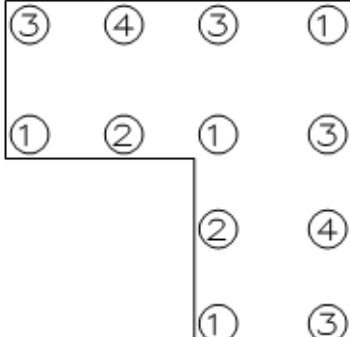
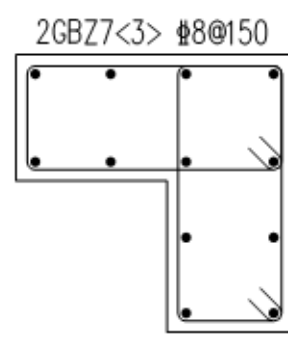

Φ8: 200x350

Φ8: L200

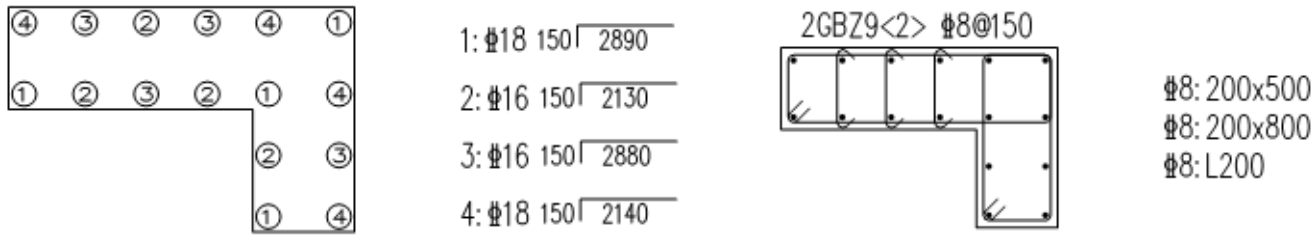
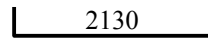
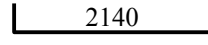
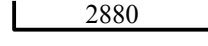
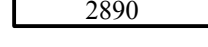
2GBZ5<7>	Φ16	150  2130	2250	4*7	28	99.54	下插920
	Φ16	150  2880	3000	4*7	28	132.72	同上
	Φ8	200  350	1240	5*7	35	17.14	
	Φ8	200	360	6*7	42	5.97	

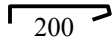
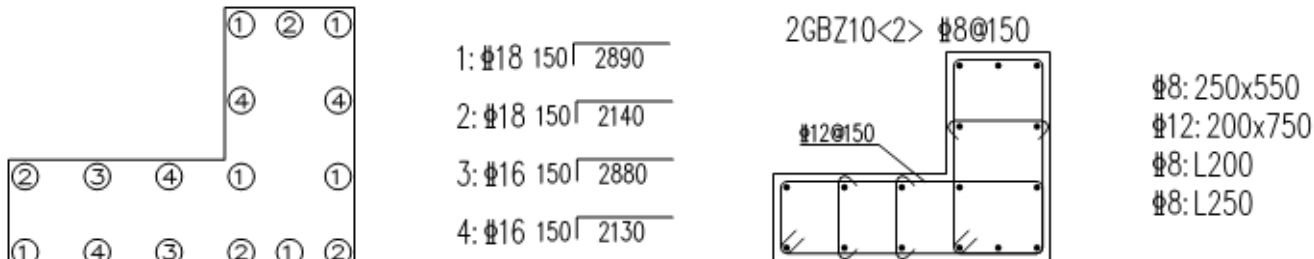
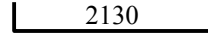
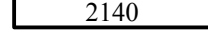
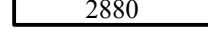
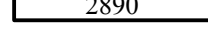
构件名称	级直别径	钢筋简图	下料 (mm)	根件 数*数	总 根数	重量 (kg)	备注
 <p>1: <math>\Phi 20</math> 150 <math>\sqrt{2890}</math>  2: <math>\Phi 20</math> 150 <math>\sqrt{2140}</math>  3: <math>\Phi 18</math> 150 <math>\sqrt{2140}</math>  4: <math>\Phi 18</math> 150 <math>\sqrt{2890}</math></p>  <p>2GBZ6&lt;2&gt; <math>\Phi 8@150</math></p> <p><math>\Phi 8</math>: 180x500  <math>\Phi 8</math>: 450x500  <math>\Phi 8</math>: 200x1000  <math>\Phi 8</math>: L200  <math>\Phi 8</math>: L450</p>							
2GBZ6<2>	$\Phi 20$	150 $\sqrt{2140}$	2250	6*2	12	66.69	下插920
	$\Phi 18$	150 $\sqrt{2140}$	2250	4*2	8	36.00	同上
	$\Phi 20$	150 $\sqrt{2890}$	3000	6*2	12	88.92	同上
	$\Phi 18$	150 $\sqrt{2890}$	3000	4*2	8	48.00	同上
	$\Phi 8$	180 $\sqrt{500}$	1500	5*2	10	5.93	
	$\Phi 8$	450 $\sqrt{500}$	2040	5*2	10	8.06	
	$\Phi 8$	200 $\sqrt{1000}$	2540	5*2	10	10.03	
	$\Phi 8$	$\sqrt{200}$	360	9*2	18	2.56	
	$\Phi 8$	$\sqrt{450}$	610	3*2	6	1.45	
 <p>1: <math>\Phi 18</math> 150 <math>\sqrt{2890}</math>  2: <math>\Phi 16</math> 150 <math>\sqrt{2130}</math>  3: <math>\Phi 18</math> 150 <math>\sqrt{2140}</math>  4: <math>\Phi 16</math> 150 <math>\sqrt{2880}</math></p>  <p>2GBZ7&lt;3&gt; <math>\Phi 8@150</math></p> <p><math>\Phi 8</math>: 200x500</p>							
2GBZ7<2>	$\Phi 16$	150 $\sqrt{2130}$	2250	2*2	4	14.22	下插920
	$\Phi 18$	150 $\sqrt{2140}$	2250	4*2	8	36.00	同上
	$\Phi 16$	150 $\sqrt{2880}$	3000	2*2	4	18.96	同上
	$\Phi 18$	150 $\sqrt{2890}$	3000	4*2	8	48.00	同上
	$\Phi 8$	200 $\sqrt{500}$	1540	10*2	20	12.17	

构件名称	级直径	钢筋简图	下料 (mm)	根件 数*数	总 根数	重量 (kg)	备注
<div style="display: flex; justify-content: space-between; align-items: flex-start;"> <div style="text-align: center;"> </div> <div style="text-align: center;"> <p>2GBZ7 <math>\Phi 8@150</math></p> </div> <div style="text-align: center;"> <p><math>\Phi 8: 200 \times 500</math></p> </div> </div> <div style="margin-top: 10px;"> <p>1: <math>\Phi 18</math> 150 <math>\sqrt{\quad}</math> 4710</p> <p>2: <math>\Phi 16</math> 150 <math>\sqrt{\quad}</math> 3950</p> <p>3: <math>\Phi 18</math> 150 <math>\sqrt{\quad}</math> 3960</p> <p>4: <math>\Phi 16</math> 150 <math>\sqrt{\quad}</math> 4700</p> </div>							
2GBZ7 用于2/12交 M轴	$\Phi 16$	150 $\sqrt{\quad}$ 3950	4070	2	2	12.86	下插2740
	$\Phi 18$	150 $\sqrt{\quad}$ 3960	4070	4	4	32.56	同上
	$\Phi 16$	150 $\sqrt{\quad}$ 4700	4820	2	2	15.23	同上
	$\Phi 18$	150 $\sqrt{\quad}$ 4710	4820	4	4	38.56	同上
	$\Phi 8$	200 $\sqrt{\quad}$ 500	1540	30	30	18.25	
<div style="display: flex; justify-content: space-between; align-items: flex-start;"> <div style="text-align: center;"> </div> <div style="text-align: center;"> <p>2GBZ8&lt;2&gt; <math>\Phi 8@150</math></p> </div> <div style="text-align: center;"> <p><math>\Phi 8: 200 \times 500</math> <math>\Phi 8: 200 \times 850</math> <math>\Phi 8: L200</math></p> </div> </div> <div style="margin-top: 10px;"> <p>1: <math>\Phi 18</math> 150 <math>\sqrt{\quad}</math> 2890</p> <p>2: <math>\Phi 18</math> 150 <math>\sqrt{\quad}</math> 2140</p> <p>3: <math>\Phi 16</math> 150 <math>\sqrt{\quad}</math> 2880</p> <p>4: <math>\Phi 16</math> 150 <math>\sqrt{\quad}</math> 2130</p> </div>							
2GBZ8<2>	$\Phi 16$	150 $\sqrt{\quad}$ 2130	2250	3*2	6	21.33	下插920
	$\Phi 18$	150 $\sqrt{\quad}$ 2140	2250	5*2	10	45.00	同上
	$\Phi 16$	150 $\sqrt{\quad}$ 2880	3000	3*2	6	28.44	同上
	$\Phi 18$	150 $\sqrt{\quad}$ 2890	3000	5*2	10	60.00	同上
	$\Phi 8$	200 $\sqrt{\quad}$ 500	1540	5*2	10	6.08	
	$\Phi 8$	200 $\sqrt{\quad}$ 850	2240	5*2	10	8.85	
	$\Phi 8$	$\sqrt{\quad}$ 200	360	9*2	18	2.56	

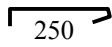
构件名称	级直别径	钢筋简图	下料 (mm)	根件 数*数	总 根数	重量 (kg)	备 注
							
2GBZ9<2>	Φ16	150 	2250	4*2	8	28.44	下插920
	Φ18	150 	2250	4*2	8	36.00	同上
	Φ16	150 	3000	4*2	8	37.92	同上
	Φ18	150 	3000	4*2	8	48.00	同上
	Φ8	200 	1540	5*2	10	6.08	
	Φ8	200 	2140	5*2	10	8.45	
	Φ8		360	9*2	18	2.56	
							
2GBZ10<2>	Φ16	150 	2250	4*2	8	28.44	下插920
	Φ18	150 	2250	4*2	8	36.00	同上
	Φ16	150 	3000	2*2	4	18.96	同上
	Φ18	150 	3000	6*2	12	72.00	同上
	Φ8	250 	1740	5*2	10	6.87	
	Φ12	200 	2120	5*2	10	18.83	
	Φ8		360	6*2	12	1.71	
	Φ8		410	3*2	6	0.97	

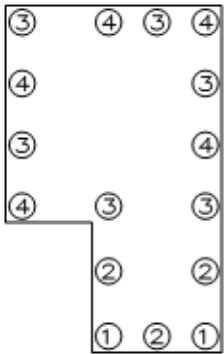
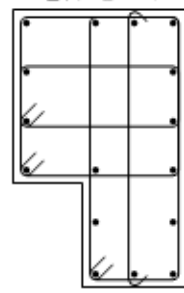
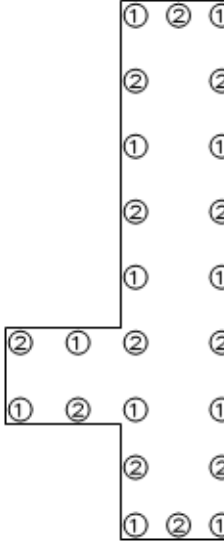
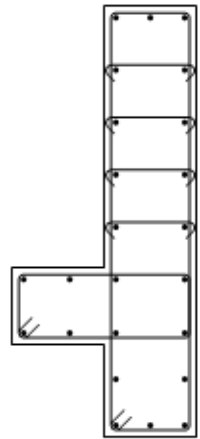
构件名称	级直别径	钢筋简图	下料 (mm)	根件 数*数	总 根数	重量 (kg)	备注
		 <p>1: <math>\Phi 18</math> 150 <math>\sqrt{\quad}</math> 5210  2: <math>\Phi 18</math> 150 <math>\sqrt{\quad}</math> 4460  3: <math>\Phi 20</math> 150 <math>\sqrt{\quad}</math> 5210  4: <math>\Phi 20</math> 150 <math>\sqrt{\quad}</math> 4460</p>					
							<p>2GBZ11 <math>\Phi 8@150</math></p>  <p><math>\Phi 8</math>: 180x450  <math>\Phi 8</math>: 450x450  <math>\Phi 8</math>: 250x750  <math>\Phi 8</math>: L750</p>
2GBZ11	$\Phi 18$	150 $\sqrt{\quad}$ 4460	4570	3	3	27.42	下插3240
	$\Phi 20$	150 $\sqrt{\quad}$ 4460	4570	5	5	56.44	同上
	$\Phi 18$	150 $\sqrt{\quad}$ 5210	5320	2	2	21.28	同上
	$\Phi 20$	150 $\sqrt{\quad}$ 5210	5320	6	6	78.84	同上
	$\Phi 8$	180 $\sqrt{\quad}$ 450	1400	15	15	8.30	
	$\Phi 8$	450 $\sqrt{\quad}$ 450	1940	18	18	13.79	
	$\Phi 8$	250 $\sqrt{\quad}$ 750	2140	18	18	15.22	
	$\Phi 8$	$\sqrt{\quad}$ 750	910	15	15	5.39	
		 <p>1: <math>\Phi 18</math> 150 <math>\sqrt{\quad}</math> 2890  2: <math>\Phi 18</math> 150 <math>\sqrt{\quad}</math> 2140</p>					
							<p>2GBZ12&lt;2&gt; <math>\Phi 8@150</math></p>  <p><math>\Phi 8</math>: 200x550  <math>\Phi 8</math>: 250x1350  <math>\Phi 8</math>: L250</p>
2GBZ12<2>	$\Phi 18$	150 $\sqrt{\quad}$ 2140	2250	12*2	24	108.00	下插920
	$\Phi 18$	150 $\sqrt{\quad}$ 2890	3000	12*2	24	144.00	同上
	$\Phi 8$	200 $\sqrt{\quad}$ 550	1640	5*2	10	6.48	
	$\Phi 8$	250 $\sqrt{\quad}$ 1350	3340	5*2	10	13.19	

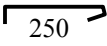
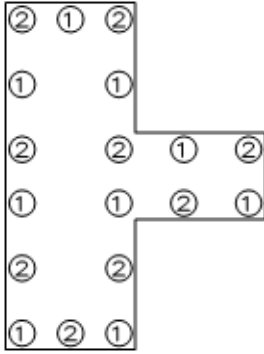
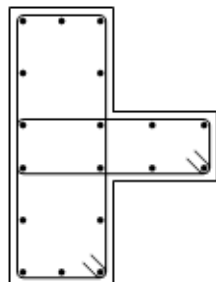
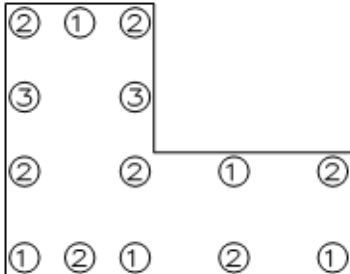
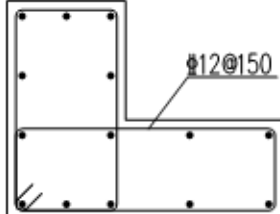
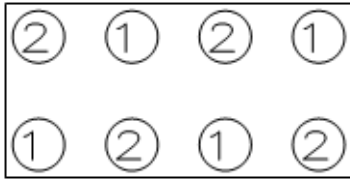
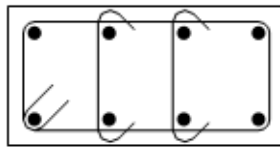

构件名称	级直径	钢筋简图	下料 (mm)	根件 数*数	总 根数	重量 (kg)	备注
	Φ8		410	12*2	24	3.89	
<div style="display: flex; justify-content: space-between; align-items: flex-start;"> <div style="text-align: center;">  <p>1: Φ16 150┐ 2880 2: Φ16 150┐ 2130</p> </div> <div style="text-align: center;"> <p>2GBZ13&lt;2&gt; Φ8@150</p>  <p>Φ8: 150x550 Φ8: 250x750</p> </div> </div>							
2GBZ13<2>	Φ16	150┐ 2130	2250	9*2	18	63.99	下插920
	Φ16	150┐ 2880	3000	9*2	18	85.32	同上
	Φ8	150┐ 550	1540	5*2	10	6.08	
	Φ8	250┐ 750	2140	5*2	10	8.45	
<div style="display: flex; justify-content: space-between; align-items: flex-start;"> <div style="text-align: center;">  <p>1: Φ18 150┐ 2890 2: Φ18 150┐ 2140 3: Φ16 150┐ 2880</p> </div> <div style="text-align: center;"> <p>2GBZ14&lt;2&gt; Φ8@150</p>  <p>Φ12: 200x650 Φ8: 250x500</p> </div> </div>							
2GBZ14<2>	Φ18	150┐ 2140	2250	7*2	14	63.00	下插920
	Φ16	150┐ 2880	3000	2*2	4	18.96	同上
	Φ18	150┐ 2890	3000	5*2	10	60.00	同上
	Φ12	200┐ 650	1920	5*2	10	17.05	
	Φ8	250┐ 500	1640	5*2	10	6.48	
<div style="display: flex; justify-content: space-between; align-items: flex-start;"> <div style="text-align: center;">  <p>1: Φ16 150┐ 2880 2: Φ16 150┐ 2130</p> </div> <div style="text-align: center;"> <p>2GBZ15&lt;3&gt; Φ8@150</p>  <p>Φ8: 150x350 Φ8: L150</p> </div> </div>							
2GBZ15<3>	Φ16	150┐ 2130	2250	4*3	12	42.66	下插920
	Φ16	150┐ 2880	3000	4*3	12	56.88	同上
	Φ8	150┐ 350	1140	5*3	15	6.75	

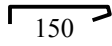
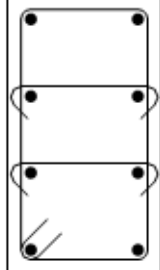
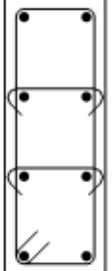
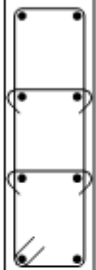
构件名称	级直径	钢筋简图	下料 (mm)	根件 数*数	总 根数	重量 (kg)	备注
	Φ8		310	6*3	18	2.20	
<div style="display: flex; justify-content: space-between; align-items: flex-start;"> <div style="border: 1px solid black; padding: 5px;"> <p>② ①</p> <p>① ②</p> <p>② ①</p> <p>① ②</p> </div> <div style="text-align: center;"> <p>2GBZ16&lt;4&gt; Φ8@150</p>  </div> <div style="text-align: right;"> <p>Φ8: 200x400 Φ8: L200</p> </div> </div> <p style="margin-top: 10px;">1: Φ16 150┐ 2880</p> <p style="margin-top: 5px;">2: Φ16 150┐ 2130</p>							
2GBZ16<4>	Φ16	150┐ 2130	2250	4*4	16	56.88	下插920
	Φ16	150┐ 2880	3000	4*4	16	75.84	同上
	Φ8	200┐ 400	1340	5*4	20	10.59	
	Φ8	┐ 200	360	6*4	24	3.41	
<div style="display: flex; justify-content: space-between; align-items: flex-start;"> <div style="border: 1px solid black; padding: 5px;"> <p>② ①</p> <p>① ②</p> <p>② ①</p> <p>① ②</p> </div> <div style="text-align: center;"> <p>2GBZ17 Φ8@150</p>  </div> <div style="text-align: right;"> <p>Φ8: 150x500 Φ8: L150</p> </div> </div> <p style="margin-top: 10px;">1: Φ16 150┐ 2880</p> <p style="margin-top: 5px;">2: Φ16 150┐ 2130</p>							
2GBZ17	Φ16	150┐ 2130	2250	4	4	14.22	下插920
	Φ16	150┐ 2880	3000	4	4	18.96	同上
	Φ8	150┐ 500	1440	5	5	2.84	
	Φ8	┐ 150	310	6	6	0.73	
<div style="display: flex; justify-content: space-between; align-items: flex-start;"> <div style="border: 1px solid black; padding: 5px;"> <p>④ ③</p> <p>③ ④</p> <p>② ①</p> <p>① ②</p> </div> <div style="text-align: center;"> <p>2GBZ18 Φ8@150</p>  </div> <div style="text-align: right;"> <p>Φ8: 150x570 Φ8: L150</p> </div> </div> <p style="margin-top: 10px;">1: Φ16 150┐ 2880</p> <p style="margin-top: 5px;">2: Φ16 150┐ 2130</p> <p style="margin-top: 5px;">3: Φ16 150┐ 5200</p> <p style="margin-top: 5px;">4: Φ16 150┐ 4450</p>							
2GBZ18	Φ16	150┐ 2130	2250	2	2	7.11	下插920

构件名称	级直径	钢筋简图	下料 (mm)	根件 数*数	总 根数	重量 (kg)	备 注
	Φ16	150	3000	2	2	9.48	同上
	Φ16	150	4570	2	2	14.44	下插3240
	Φ16	150	5320	2	2	16.81	同上
	Φ8	150	1580	5	5	3.12	
	Φ8		310	6	6	0.73	

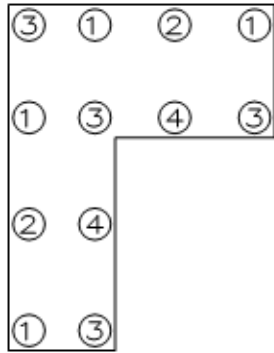

- 1: Φ18 150
- 2: Φ16 150
- 3: Φ18 150
- 4: Φ16 150

2GBZ19 Φ8@150

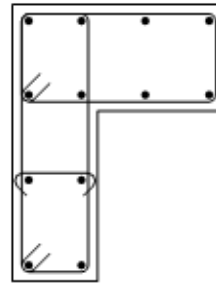

Φ8: 150x600  
Φ8: 200x450  
Φ8: L150

2GBZ19 用于2/6交M 轴	Φ16	150	4570	2	2	14.44	下插3240
	Φ18	150	4570	4	4	36.56	同上
	Φ16	150	5320	2	2	16.81	同上
	Φ18	150	5320	4	4	42.56	同上
	Φ8	150	1640	18	18	11.66	
	Φ8	200	1440	18	18	10.24	
	Φ8		310	15	15	1.84	

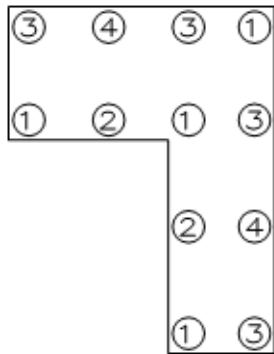

- 1: Φ18 150
- 2: Φ16 150
- 3: Φ18 150
- 4: Φ16 150

2GBZ19 Φ8@150

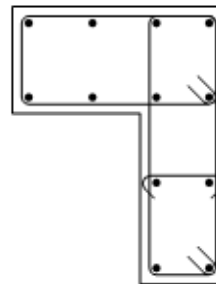







Φ8: 150x600  
Φ8: 200x450  
Φ8: L150

2GBZ19 用于2/14交 M轴	Φ16	150	4070	2	2	12.86	下插2740
	Φ18	150	4070	4	4	32.56	同上
	Φ16	150	4820	2	2	15.23	同上

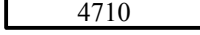
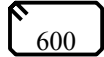
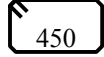
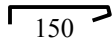
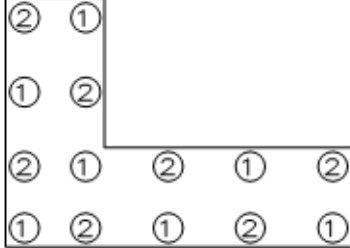
审核:

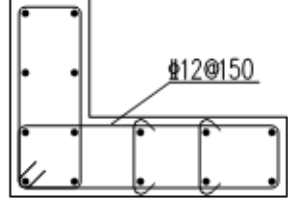
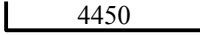
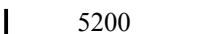
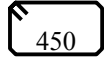
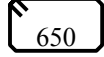
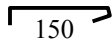
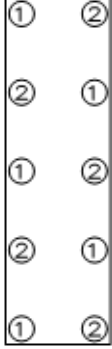
翻样: 钟祥祯13653434429

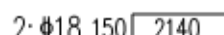
第 34 页,共43页

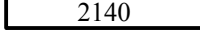
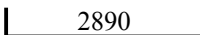
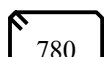
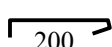
构件名称	级直径	钢筋简图	下料 (mm)	根件 数*数	总 根数	重量 (kg)	备注
	Φ18	150 	4820	4	4	38.56	同上
	Φ8	150 	1640	15	15	9.72	
	Φ8	200 	1440	15	15	8.53	
	Φ8		310	13	13	1.59	
<div style="display: flex; justify-content: space-between; align-items: flex-start;"> <div style="text-align: center;">  <p>1: Φ16 150 </p> <p>2: Φ16 150 </p> </div> <div style="text-align: center;"> <p>2GBZ20 Φ8@150</p>  </div> <div style="text-align: right;"> <p>Φ8: 150x450 Φ12: 150x650 Φ8: L150</p> </div> </div>							
2GBZ20	Φ16	150 	4570	7	7	50.54	下插3240
	Φ16	150 	5320	7	7	58.84	同上
	Φ8	150 	1340	18	18	9.53	
	Φ12	150 	1820	18	18	29.09	
	Φ8		310	30	30	3.67	
<div style="display: flex; justify-content: space-between; align-items: flex-start;"> <div style="text-align: center;">  <p>1: Φ18 150 </p> <p>2: Φ18 150 </p> </div> <div style="text-align: center;"> <p>2GBZ21&lt;2&gt; Φ8@150</p>  </div> <div style="text-align: right;"> <p>Φ8: 200x780 Φ8: L200</p> </div> </div>							
2GBZ21<2>	Φ18	150 	2250	5*2	10	45.00	下插920
	Φ18	150 	3000	5*2	10	60.00	同上
	Φ8	200 	2100	5*2	10	8.30	
	Φ8		360	9*2	18	2.56	

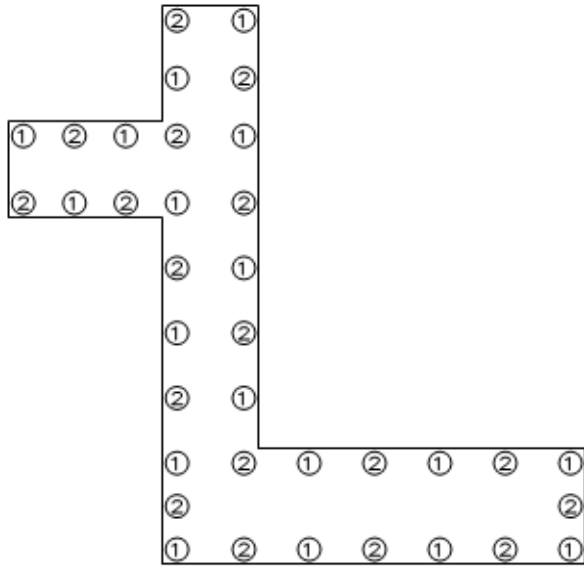
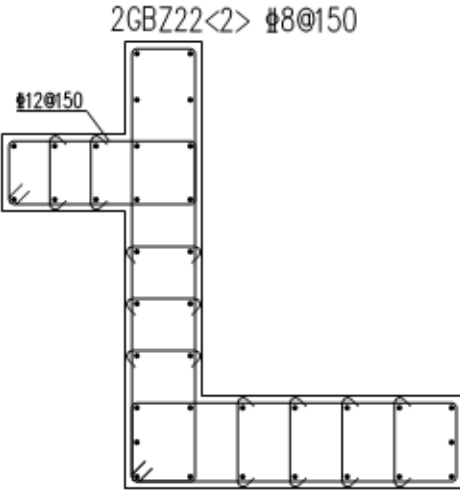
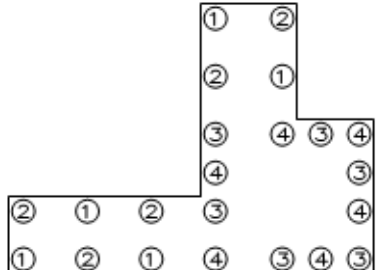
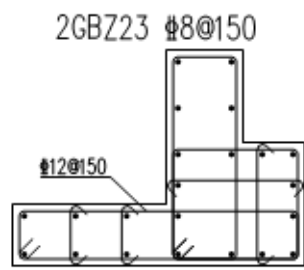
构件名称	级直别径	钢筋简图	下料 (mm)	根件 数*数	总 根数	重量 (kg)	备注
		 <p>1: <math>\Phi 18</math> 150 <math>\sqrt{2890}</math>      2: <math>\Phi 18</math> 150 <math>\sqrt{2140}</math></p>					
							$\Phi 12$ : 200x600 $\Phi 8$ : 200x1400 $\Phi 8$ : 250x1050 $\Phi 8$ : L200 $\Phi 8$ : L250
2GBZ22<2>	$\Phi 18$	150 $\sqrt{2140}$	2250	18*2	36	162.00	下插920
	$\Phi 18$	150 $\sqrt{2890}$	3000	18*2	36	216.00	同上
	$\Phi 12$	200 $\sqrt{600}$	1820	5*2	10	16.16	
	$\Phi 8$	200 $\sqrt{1400}$	3340	5*2	10	13.19	
	$\Phi 8$	250 $\sqrt{1050}$	2740	5*2	10	10.82	
	$\Phi 8$	$\sqrt{200}$	360	15*2	30	4.27	
	$\Phi 8$	$\sqrt{250}$	410	12*2	24	3.89	
		 <p>1: <math>\Phi 16</math> 150 <math>\sqrt{4700}</math>  2: <math>\Phi 16</math> 150 <math>\sqrt{3950}</math>  3: <math>\Phi 18</math> 150 <math>\sqrt{4710}</math>  4: <math>\Phi 18</math> 150 <math>\sqrt{3960}</math></p>					
							$\Phi 8$ : 200x650 $\Phi 8$ : 350x400 $\Phi 12$ : 150x900 $\Phi 8$ : L150 $\Phi 8$ : L350 $\Phi 8$ : L400
2GBZ23	$\Phi 16$	150 $\sqrt{3950}$	4070	5	5	32.15	下插2740
	$\Phi 18$	150 $\sqrt{3960}$	4070	6	6	48.84	同上
	$\Phi 16$	150 $\sqrt{4700}$	4820	5	5	38.08	同上
	$\Phi 18$	150 $\sqrt{4710}$	4820	6	6	57.84	同上
	$\Phi 8$	200 $\sqrt{650}$	1840	15	15	10.90	

构件名称	级直径	钢筋简图	下料 (mm)	根件 数*数	总 根数	重量 (kg)	备注
	Φ8	350 	1640	15	15	9.72	
	Φ12	150 	2320	15	15	30.90	
	Φ8		310	26	26	3.18	
	Φ8		510	13	13	2.62	
	Φ8		560	13	13	2.88	

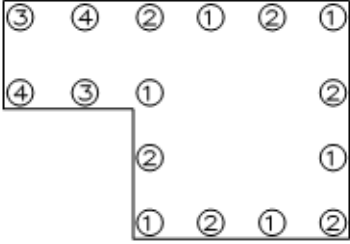

1: Φ20 150 

2: Φ20 150 

3: Φ18 150 

4: Φ18 150 

2GBZ24 Φ8@150

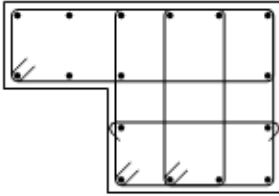

Φ8: 180x500  
Φ8: 450x500  
Φ8: 200x750  
Φ8: L450

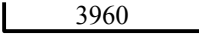
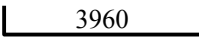
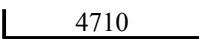
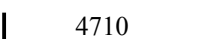
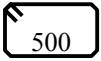
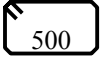
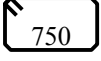
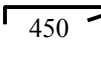
2GBZ24	Φ20	150 	4070	6	6	60.32	下插2740
	Φ18	150 	4070	2	2	16.28	同上
	Φ20	150 	4820	6	6	71.43	同上
	Φ18	150 	4820	2	2	19.28	同上
	Φ8	180 	1500	13	13	7.70	
	Φ8	450 	2040	15	15	12.09	
	Φ8	200 	2040	15	15	12.09	
	Φ8		610	13	13	3.13	

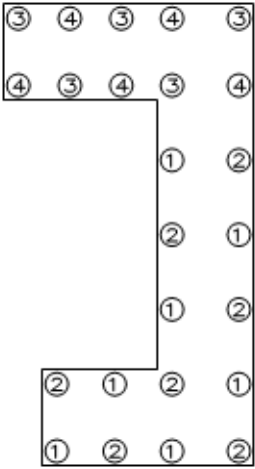

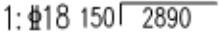
1: Φ18 150 

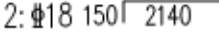
2: Φ18 150 

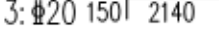
3: Φ20 150 

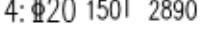
4: Φ20 150 

2GBZ25<2> Φ8@150

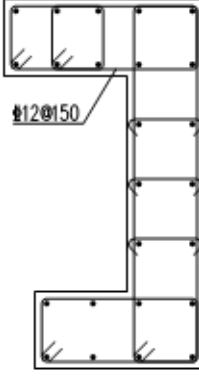

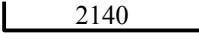

Φ8: 170x200  
Φ8: 200x500  
Φ12: 200x600  
Φ8: 200x1150  
Φ8: L200

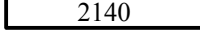
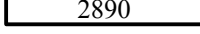
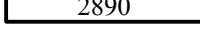
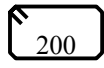
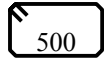
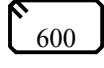
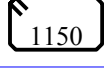
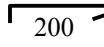
2GBZ25<2>	Φ18	150 	2250	7*2	14	63.00	下插920
-----------	-----	---	------	-----	----	-------	-------

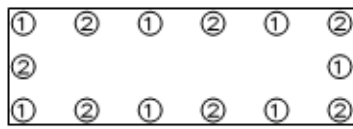
构件名称	级直径	钢筋简图	下料 (mm)	根件 数*数	总 根数	重量 (kg)	备 注
	Φ20	150  2140	2250	5*2	10	55.58	同上
	Φ18	150  2890	3000	7*2	14	84.00	同上
	Φ20	150  2890	3000	5*2	10	74.10	同上
	Φ8	170  200	880	3*2	6	2.09	
	Φ8	200  500	1540	5*2	10	6.08	
	Φ12	200  600	1820	5*2	10	16.16	
	Φ8	200  1150	2840	5*2	10	11.22	
	Φ8	 200	360	9*2	18	2.56	

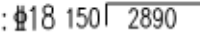



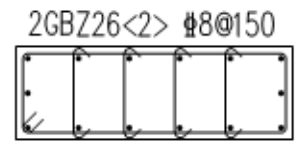

1: Φ18 150  2890  
2: Φ18 150  2140

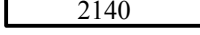
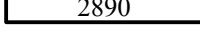
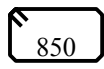
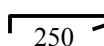

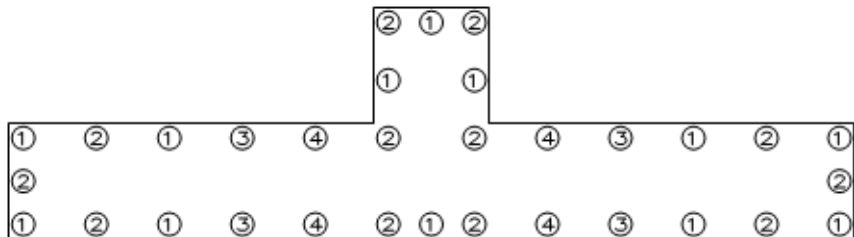
Φ8: 250x850  
Φ8: L250

2GBZ26<2>	Φ18	150  2140	2250	7*2	14	63.00	下插920
	Φ18	150  2890	3000	7*2	14	84.00	同上
	Φ8	250  850	2340	5*2	10	9.24	
	Φ8	 250	410	12*2	24	3.89	





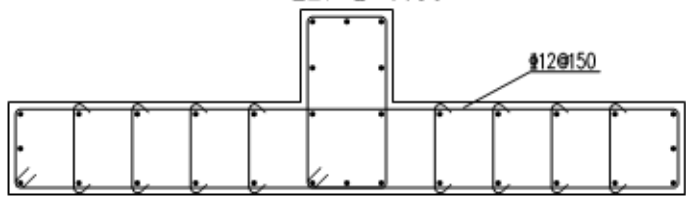

1: Φ20 150  2890  
2: Φ20 150  2140  
3: Φ18 150  2140  
4: Φ18 150  2890

2GBZ27 Φ8@150

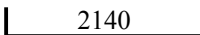
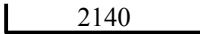
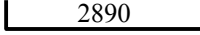
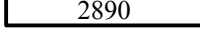

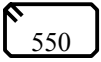
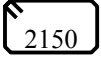
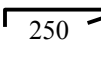
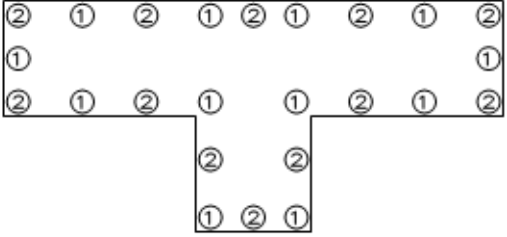
Φ8: 250x550  
Φ12: 250x2150  
Φ8: L250

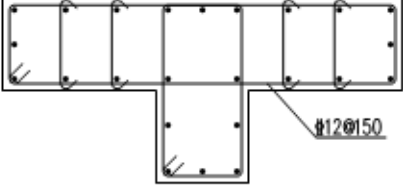
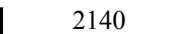
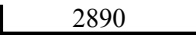
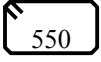
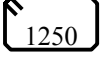
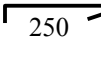
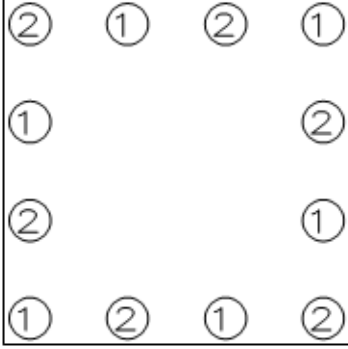

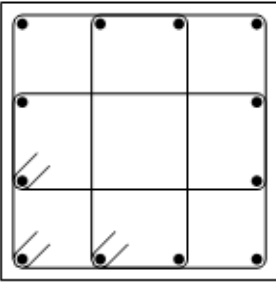
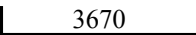
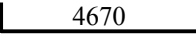
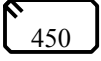
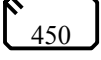
2GBZ27	Φ20	150  2140	2250	12	12	66.69	下插920
	Φ18	150  2140	2250	4	4	18.00	同上
	Φ20	150  2890	3000	12	12	88.92	同上
	Φ18	150  2890	3000	4	4	24.00	同上

构件名称	级直径	钢筋简图	下料 (mm)	根件 数*数	总 根数	重量 (kg)	备注
	Φ8	250 	1740	5	5	3.44	
	Φ12	250 	5020	5	5	22.29	
	Φ8		410	15	15	2.43	
<div style="display: flex; justify-content: space-between; align-items: flex-start;"> <div style="text-align: center;">  <p>1: Φ18 150  2890 2: Φ18 150  2140</p> </div> <div style="text-align: center;"> <p>2GBZ28 Φ8@150</p>  <p>Φ8: 250x550 Φ12: 250x1250 Φ8: L250</p> </div> </div>							
2GBZ28	Φ18	150 	2250	12	12	54.00	下插920
	Φ18	150 	3000	12	12	72.00	同上
	Φ8	250 	1740	5	5	3.44	
	Φ12	250 	3220	5	5	14.30	
	Φ8		410	12	12	1.94	
<div style="display: flex; justify-content: space-between; align-items: flex-start;"> <div style="text-align: center;">  <p>1: Φ25 150  # 2: Φ25 150  #</p> </div> <div style="text-align: center;"> <p>2GBZ29 Φ8@100</p>  <p>Φ8: 180x450 Φ8: 450x450</p> </div> </div>							
2GBZ29	Φ25	150 	3770	6	6	87.09	下插2740
	Φ25	150 	4770	6	6	110.19	同上
	Φ8	180 	1400	26	26	14.38	
	Φ8	450 	1940	15	15	11.49	

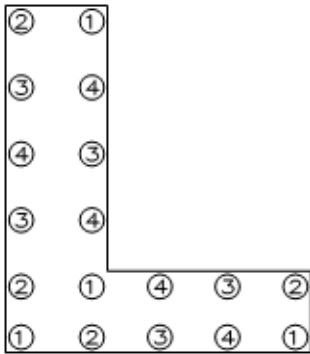
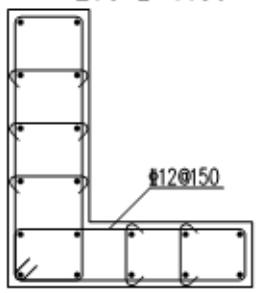
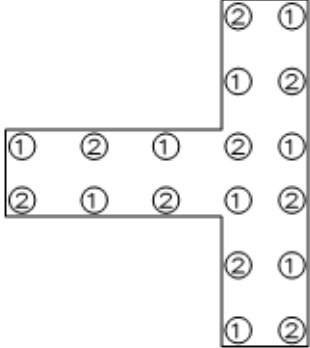
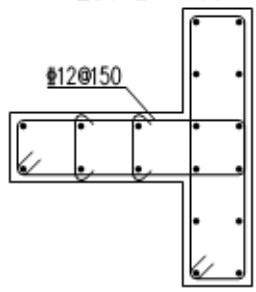

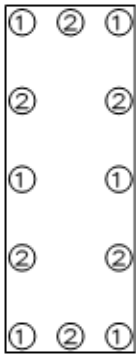
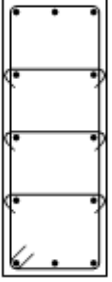
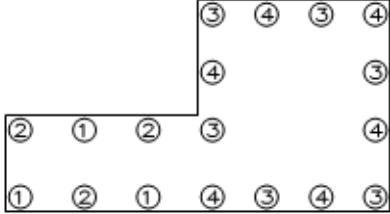
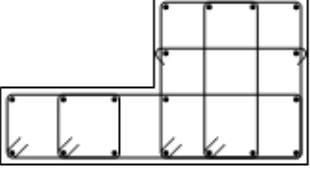
构件名称	级直径	钢筋简图	下料 (mm)	根件 数*数	总 根数	重量 (kg)	备注
		 <p>2GBZ30 <math>\Phi 8@150</math></p> <p>1: <math>\Phi 18</math> 150 <math>\sqrt{4710}</math>  2: <math>\Phi 18</math> 150 <math>\sqrt{3960}</math>  3: <math>\Phi 16</math> 150 <math>\sqrt{4700}</math>  4: <math>\Phi 16</math> 150 <math>\sqrt{3950}</math></p>  <p><math>\Phi 12</math>: 150x700  <math>\Phi 8</math>: 200x800  <math>\Phi 8</math>: L150  <math>\Phi 8</math>: L200</p>					
2GBZ30	$\Phi 16$	150 $\sqrt{3950}$	4070	5	5	32.15	下插2740
	$\Phi 18$	150 $\sqrt{3960}$	4070	4	4	32.56	同上
	$\Phi 16$	150 $\sqrt{4700}$	4820	5	5	38.08	同上
	$\Phi 18$	150 $\sqrt{4710}$	4820	4	4	38.56	同上
	$\Phi 12$	150 $\sqrt{700}$	1920	15	15	25.57	
	$\Phi 8$	200 $\sqrt{800}$	2140	15	15	12.68	
	$\Phi 8$	$\sqrt{150}$	310	26	26	3.18	
	$\Phi 8$	$\sqrt{200}$	360	39	39	5.55	
		 <p>2GBZ31 <math>\Phi 8@150</math></p> <p>1: <math>\Phi 16</math> 150 <math>\sqrt{4700}</math>  2: <math>\Phi 16</math> 150 <math>\sqrt{3950}</math></p>  <p><math>\Phi 12</math>: 150x650  <math>\Phi 8</math>: 150x750  <math>\Phi 8</math>: L150</p>					
2GBZ31	$\Phi 16$	150 $\sqrt{3950}$	4070	9	9	57.88	下插2740
	$\Phi 16$	150 $\sqrt{4700}$	4820	9	9	68.54	同上
	$\Phi 12$	150 $\sqrt{650}$	1820	15	15	24.24	
	$\Phi 8$	150 $\sqrt{750}$	1940	15	15	11.49	
	$\Phi 8$	$\sqrt{150}$	310	26	26	3.18	

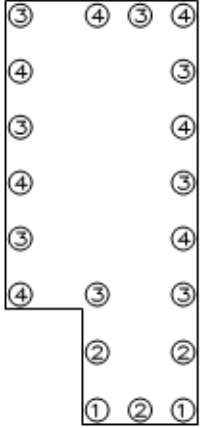
构件名称	级直径	钢筋简图	下料 (mm)	根件 数*数	总 根数	重量 (kg)	备注
		 <p>2GBZ32 <math>\Phi 8@150</math></p> <p>1: <math>\Phi 18</math> 150 <math>\lrcorner</math> 2890 2: <math>\Phi 18</math> 150 <math>\lrcorner</math> 2140</p>  <p><math>\Phi 8</math>: 250x750 <math>\Phi 8</math>: L250</p>					
2GBZ32	$\Phi 18$	150 $\lrcorner$ 2140	2250	6	6	27.00	下插920
	$\Phi 18$	150 $\lrcorner$ 2890	3000	6	6	36.00	同上
	$\Phi 8$	250 $\lrcorner$ 750	2140	5	5	4.23	
	$\Phi 8$	$\lrcorner$ 250	410	9	9	1.46	
		 <p>2GBZ33 <math>\Phi 8@150</math></p> <p>1: <math>\Phi 18</math> 150 <math>\lrcorner</math> 2890 2: <math>\Phi 18</math> 150 <math>\lrcorner</math> 2140 3: <math>\Phi 20</math> 150 <math>\lrcorner</math> 2890 4: <math>\Phi 20</math> 150 <math>\lrcorner</math> 2140</p>  <p><math>\Phi 8</math>: 200x200 <math>\Phi 8</math>: 180x500 <math>\Phi 8</math>: 450x500 <math>\Phi 8</math>: 200x950 <math>\Phi 8</math>: L450</p>					
2GBZ33	$\Phi 18$	150 $\lrcorner$ 2140	2250	3	3	13.50	下插920
	$\Phi 20$	150 $\lrcorner$ 2140	2250	6	6	33.35	同上
	$\Phi 18$	150 $\lrcorner$ 2890	3000	3	3	18.00	同上
	$\Phi 20$	150 $\lrcorner$ 2890	3000	6	6	44.46	同上
	$\Phi 8$	200 $\lrcorner$ 200	940	3	3	1.11	
	$\Phi 8$	180 $\lrcorner$ 500	1500	3	3	1.78	
	$\Phi 8$	450 $\lrcorner$ 500	2040	5	5	4.03	
	$\Phi 8$	200 $\lrcorner$ 950	2440	5	5	4.82	
	$\Phi 8$	$\lrcorner$ 450	610	3	3	0.72	

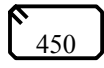
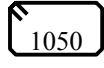
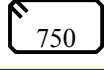
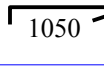
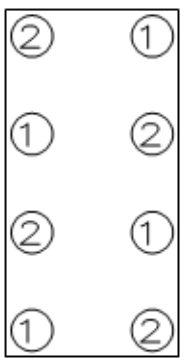
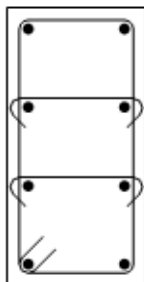
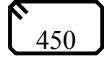
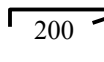
构件名称	级直 别径	钢筋简图	下料 (mm)	根件 数*数	总 根数	重量 (kg)	备 注
<div style="display: flex; justify-content: space-between; align-items: flex-start;"> <div style="text-align: center;">  </div> <div style="text-align: center;"> <p>2GBZ34 <math>\Phi 8@150</math></p>  </div> <div style="text-align: center;"> <p>1: <math>\Phi 18</math> 150 <math>\lrcorner</math> 2890  2: <math>\Phi 18</math> 150 <math>\lrcorner</math> 2140  3: <math>\Phi 20</math> 150 <math>\lrcorner</math> 2890  4: <math>\Phi 20</math> 150 <math>\lrcorner</math> 2140</p> </div> <div style="text-align: center;"> <p><math>\Phi 8</math>: 180x450  <math>\Phi 8</math>: 250x1050  <math>\Phi 8</math>: 450x750  <math>\Phi 8</math>: L1050</p> </div> </div>							
2GBZ34	$\Phi 18$	150 $\lrcorner$ 2140	2250	3	3	13.50	下插920
	$\Phi 20$	150 $\lrcorner$ 2140	2250	7	7	38.90	同上
	$\Phi 18$	150 $\lrcorner$ 2890	3000	2	2	12.00	同上
	$\Phi 20$	150 $\lrcorner$ 2890	3000	8	8	59.28	同上
	$\Phi 8$	180 	1400	6	6	3.32	
	$\Phi 8$	250 	2740	5	5	5.41	
	$\Phi 8$	450 	2540	5	5	5.02	
	$\Phi 8$	 1050	1210	3	3	1.43	
<div style="display: flex; justify-content: space-between; align-items: flex-start;"> <div style="text-align: center;">  </div> <div style="text-align: center;"> <p>2GBZ35 <math>\Phi 8@150</math></p>  </div> <div style="text-align: center;"> <p>1: <math>\Phi 16</math> 150 <math>\lrcorner</math> 2880  2: <math>\Phi 16</math> 150 <math>\lrcorner</math> 2130</p> </div> <div style="text-align: center;"> <p><math>\Phi 8</math>: 200x450  <math>\Phi 8</math>: L200</p> </div> </div>							
2GBZ35	$\Phi 16$	150 $\lrcorner$ 2130	2250	4	4	14.22	下插920
	$\Phi 16$	150 $\lrcorner$ 2880	3000	4	4	18.96	同上
	$\Phi 8$	200 	1440	5	5	2.84	
	$\Phi 8$	 200	360	6	6	0.85	

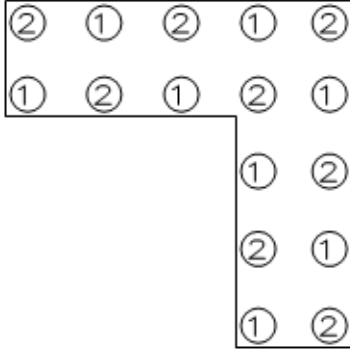
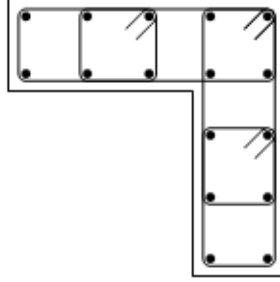
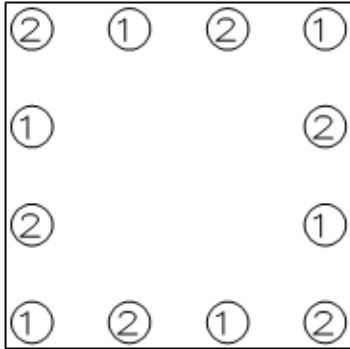
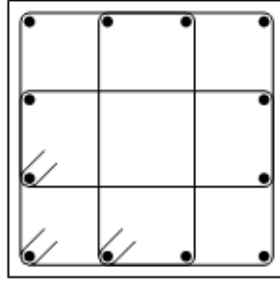
构件名称	级直径	钢筋简图	下料 (mm)	根件 数*数	总 根数	重量 (kg)	备注
<div style="display: flex; justify-content: space-between; align-items: flex-start;"> <div style="text-align: center;">  <p>1: <math>\Phi 18</math> 150 <math>\sqrt{2890}</math> 2: <math>\Phi 18</math> 150 <math>\sqrt{2140}</math></p> </div> <div style="text-align: center;"> <p>2KZ1&lt;2&gt; <math>\Phi 10@100</math></p>  </div> <div style="text-align: right;"> <p><math>\Phi 10</math>: 150x170 <math>\Phi 10</math>: 150x550</p> </div> </div>							
2KZ1<2>	$\Phi 18$	150 $\sqrt{2140}$	2250	8*2	16	72.00	下插920
	$\Phi 18$	150 $\sqrt{2890}$	3000	8*2	16	96.00	同上
	$\Phi 10$	150 $\sqrt{170}$	820	6*2	12	6.07	
	$\Phi 10$	150 $\sqrt{550}$	1580	10*2	20	19.50	
<div style="display: flex; justify-content: space-between; align-items: flex-start;"> <div style="text-align: center;">  <p>1: <math>\Phi 18</math> 150 <math>\sqrt{2890}</math> 2: <math>\Phi 18</math> 150 <math>\sqrt{2140}</math></p> </div> <div style="text-align: center;"> <p>2KZ2&lt;4&gt; <math>\Phi 10@100</math></p>  </div> <div style="text-align: right;"> <p><math>\Phi 10</math>: 180x450 <math>\Phi 10</math>: 450x450</p> </div> </div>							
2KZ2<4>	$\Phi 18$	150 $\sqrt{2140}$	2250	6*4	24	108.00	下插920
	$\Phi 18$	150 $\sqrt{2890}$	3000	6*4	24	144.00	同上
	$\Phi 10$	180 $\sqrt{450}$	1440	6*4	24	21.32	
	$\Phi 10$	450 $\sqrt{450}$	1980	5*4	20	24.43	